

bq2423x USB-Friendly Lithium-Ion Battery Charger And Power-Path Management IC

1 Features

- Fully Compliant USB Charger
 - Selectable 100-mA and 500-mA Maximum Input Current
 - 100-mA Maximum Current Limit Ensures Compliance to USB-IF Standard
 - Input-based Dynamic Power Management (V_{IN} -DPM) for Protection Against Poor USB Sources
- 28-V Input Rating With Overvoltage Protection
- Integrated Dynamic Power-Path Management (DPPM) Function Simultaneously and Independently Powers the System and Charges the Battery
- Supports up to 500-mA Charge Current With Current Monitoring Output (ISET)
- Programmable Input Current Limit up to 500 mA for Wall Adapters
- Programmable Termination Current (bq24232)
- Programmable Precharge and Fast-Charge Safety Timers
- Reverse Current, Short-Circuit, and Thermal Protection
- NTC Thermistor Input
- Proprietary Start-Up Sequence Limits Inrush Current
- Status Indication – Charging/Done, Power Good
- Small 3 mm × 3 mm 16-Lead QFN Package

2 Applications

- Bluetooth™ Devices
- Low-Power Handheld Devices

3 Description

The bq2423x series of devices are highly integrated Li-ion linear chargers and system power-path management devices targeted at space-limited portable applications. The devices operate from either a USB port or ac adapter and support charge currents between 25 mA and 500 mA. The high-input-voltage range with input overvoltage protection supports low-cost, unregulated adapters. The USB input current limit accuracy and start-up sequence allow the bq2423x to meet USB-IF inrush current specification. Additionally, the input dynamic power management (V_{IN} -DPM) prevents the charger from crashing poorly designed or incorrectly configured USB sources.

The bq2423x features dynamic power-path management (DPPM) that powers the system while simultaneously and independently charging the battery. The DPPM circuit reduces the charge current when the input current limit causes the system output to fall to the DPPM threshold, thus supplying the system load at all times while monitoring the charge current separately. This feature reduces the number of charge and discharge cycles on the battery, allows for proper charge termination, and enables the system to run with a defective or absent battery pack. Additionally, this enables instant system turn-on even with a totally discharged battery. The power-path management architecture also permits the battery to supplement the system current requirements when the adapter cannot deliver the peak system currents, enabling the use of a smaller adapter.

The battery is charged in three phases: conditioning, constant current, and constant voltage. In all charge phases, an internal control loop monitors the IC junction temperature and reduces the charge current if the internal temperature threshold is exceeded.

The charger power stage and charge current sense functions are fully integrated. The charger function has high-accuracy current and voltage regulation loops, charge status display, and charge termination. The input current limit and charge current are programmable using external resistors.

Device Information⁽¹⁾

PART NUMBER	PACKAGE	BODY SIZE (NOM)
bq24230	VQFN (16)	3.00 mm × 3.00 mm
bq24232		

(1) For all available packages, see the orderable addendum at the end of the datasheet.

Typical Application Circuit

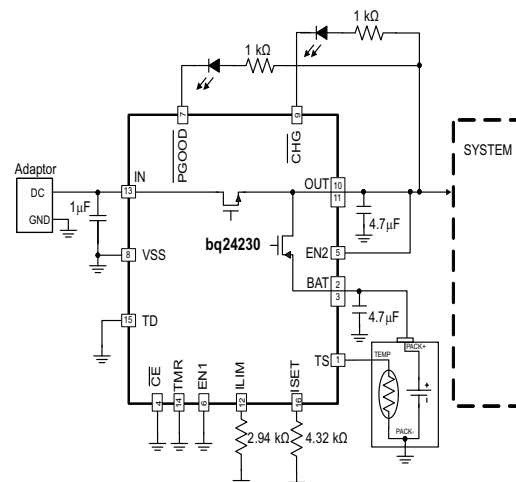

Table of Contents

1 Features 1 2 Applications 1 3 Description 1 4 Revision History 2 5 Device Comparison Table 5 6 Pin Configuration and Functions 5 7 Specifications 7 7.1 Absolute Maximum Ratings 7 7.2 ESD Ratings..... 7 7.3 Recommended Operating Conditions..... 7 7.4 Thermal Information 8 7.5 Electrical Characteristics..... 8 7.6 Timing Requirements..... 11 7.7 Typical Characteristics..... 12 8 Detailed Description 14 8.1 Overview 14 8.2 Functional Block Diagram 15 8.3 Feature Description..... 16 8.4 Device Functional Modes..... 22	9 Application and Implementation 29 9.1 Application Information..... 29 9.2 Typical Applications 29 10 Power Supply Recommendations 35 10.1 Requirements for OUT Output..... 35 10.2 USB Sources and Standard AC Adapters 35 10.3 Half-Wave Adapters 35 11 Layout 35 11.1 Layout Guidelines 35 11.2 Layout Example 36 11.3 Thermal Package 36 12 Device and Documentation Support 37 12.1 Documentation Support 37 12.2 Related Links 37 12.3 Trademarks 37 12.4 Electrostatic Discharge Caution..... 37 12.5 Glossary 37 13 Mechanical, Packaging, and Orderable Information 37
---	--

4 Revision History

NOTE: Page numbers for previous revisions may differ from page numbers in the current version.

Changes from Revision I (November 2015) to Revision J	Page
• Changed from "Table 2" to "Table 1" in the Pin Functions Description column for pins EN2/EN1	5

Changes from Revision H (June 2015) to Revision I	Page
• Changed the Pin Functions ISET pin description resistor value from 3-kΩ to 1.8-kΩ, to match the value in the Recommended Operating Conditions table.	6
• Changed K _{TMR} MIN TYP MAX values FROM "30, 40, 50" TO "36, 48, 60" s/kΩ, respectively, in the Timing Requirements table.....	11
• Changed textual content of Input Voltage Dynamic Power Management, (V_{IN_DPM}) section for clarification.	18
• Changed textual content of Dynamic Power Path Management (DPPM) section for clarification.	18
• Changed textual content of Battery Supplement Mode section for clarification.....	18
• Changed textual content of Battery Pack Temperature Monitoring section for clarification.....	21
• Added Modifying / Extending the Allowable Temperature Range for Charging sub-section heading and text for clarification.....	21
• Changed "6.25-hour" TO " 7.5-hour" Fast Charge Safety Timer in the Using The bq24232 In A Stand-Alone Charger Application section.....	29

Changes from Revision G (March 2015) to Revision H	Page
• Changed \overline{CE} pin Description in the Pin Functions table from "Connect \overline{CE} to a high logic level to place the battery charger in standby mode...." to "Connect CE to a high logic level to disable battery charging".	5
• Changed the ILIM pin Description From: "Connect a 2.75-kΩ to 8.4-kΩ resistor...." To: "Connect a 3.1-kΩ to 7.8-kΩ resistor..."	5
• Changed "I _{PRECHG} Precharge current" spec to "K _{IPRECHG} Precharge current factor" in the Electrical Characteristics table.	10
• Moved timing specifications from Electrical Characteristics table to Timing Requirements table	11
• Changed Requirements for OUT Output section text from "> VBATUVLO" to "around 2.2 V".	35

Changes from Revision F (November 2014) to Revision G **Page**

- Added text to ILIM pin description for clarification..... 5
 - Moved T_{stg} spec to Absolute Maximum Ratings table and changed Handling Ragtings table title to ESD Ratings 7
 - Deleted text string from second paragraph of Power On description for clarification 16
-

Changes from Revision E (January 2014) to Revision F **Page**

- Added Device Information and Handling Rating tables, Feature Description section, Device Functional Modes, Programming section, Application and Implementation section, Power Supply Recommendations section, Layout section, Device and Documentation Support section, and Mechanical, Packaging, and Orderable Information section 1
 - Changed V_{RCH} spec MIN, TYP, MAX terminology from $V_{O(REG)}$ to $V_{BAT(REG)}$ 10
 - Added "Reset the timers by toggling CE pin." in the Dynamic Charge timers (TMR) Input description. 25
-

Changes from Revision D (December 2013) to Revision E **Page**

- Added $T_J = 85^\circ\text{C}$ to conditions statement for $I_{BAT(PDWN)}$ specification..... 8
-

Changes from Revision C (July 2010) to Revision D **Page**

- Changed the ILIM pin Description From: "Connect a 3.1-k Ω to 7.8-k Ω resistor..." To: "Connect a 2.75-k Ω to 8.4-k Ω resistor..." 5
 - Changed POWER PATH I_{IN} max Test Condition From: $R_{ILIM} = 3.1\text{ k}\Omega$ to 7.8 k Ω To: $R_{ILIM} = 2.75\text{ k}\Omega$ to 8.4 k Ω 9
 - Changed UNITS from "ms" to "V" for V_{LOWV} specification in Electrical Characteristics table..... 10
 - Changed text following [Equation 1](#) From: The valid resistor range is 3.2 k Ω to 8 k Ω To: The valid resistor range is 2.75 k Ω to 8.4 k Ω 18
 - Changed the Program the Input Current Limit (ILIM) section: $K_{ILIM} = 1470\text{ A}\Omega$ To: $K_{ILIM} = 1530\text{ A}\Omega$ 31
 - Changed the Program the Input Current Limit (ILIM) section: $R_{ISET} = 1470\text{ A}\Omega / 0.5\text{ A} = 2.94\text{ k}\Omega$ To: $R_{ISET} = 1530\text{ A}\Omega / 0.5\text{ A} = 3.06\text{ k}\Omega$ 31
 - Changed Program the Input Current Limit (ILIM) text From: Select the closest standard value, which for this case is 2.94 k Ω To: Select the closest standard value, which for this case is 3.06 k Ω 31
-

Changes from Revision B (March 2009) to Revision C **Page**

- Changed globally RT1 and RT2 to Rs and Rp..... 21
 - Added [Equation 2](#) and [Equation 3](#), term explanations and resistance table..... 21
-

Changes from Revision A (December 2008) to Revision B **Page**

- Changed Absolute Maximum Ratings $I_{O, OUT}$ From: 600 mA To: 1700 mA..... 7
 - Changed Absolute Maximum Ratings $I_{O, BAT}$ (Discharge mode) From: 600 mA To: 1700 mA..... 7
 - Changed Recommended Operating Conditions I_{BAT} From 500 MA To: 1500 mA 7
 - Changed Recommended Operating Conditions I_{CHG} From 500 MA To: 1500 mA..... 7
 - Added POWER PATH K_{ILIM} Test Conditions: $I_{LIM} = 200\text{ mA}$ to 500 mA..... 9
 - Changed the POWER PATH K_{ILIM} Values From: MIN =1320 TYP = 1470 MAX = 1620 To: MIN = 1380 TYP = 1530 MAX =1680..... 9
 - Changed BATTERY CHARGER $V_{BAT(REG)}$ MAX value From: 4.24 To: 4.23 10
-

Changes from Original (October 2008) to Revision A**Page**

-
- Changed the second paragraph of the DESCRIPTION 1
-

5 Device Comparison Table

PART NUMBER ⁽¹⁾	V _{OVP}	V _{OUT(REG)}	V _{DPM}	OPTIONAL FUNCTION	MARKING
bq24230	6.6 V	4.4 V	V _{O(REG)} – 100 mV	TD	CGN
bq24232	10.5 V	4.4 V	V _{O(REG)} – 100 mV	ITERM	NXK

- (1) This product is RoHS compatible, including a lead concentration that does not exceed 0.1% of total product weight, and is suitable for use in specified lead-free soldering processes. In addition, this product uses package materials that do not contain halogens, including bromine (Br) or antimony (Sb) above 0.1% of total product weight.

6 Pin Configuration and Functions

16-Pin RGT Package with Thermal Pad
(Top View)

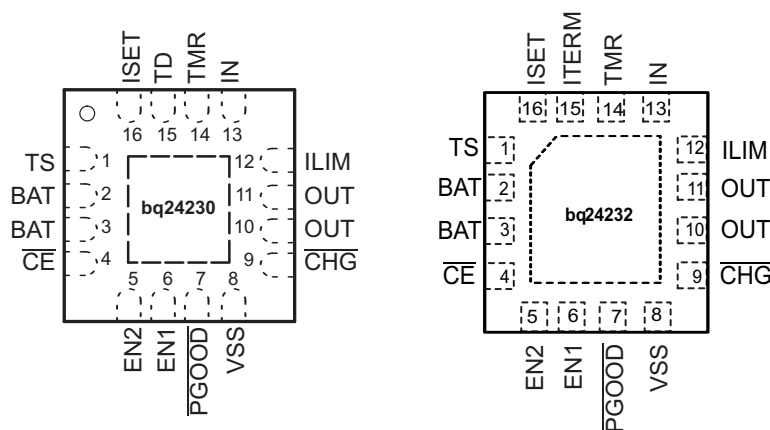

Pin Functions

NAME	PIN NUMBER		I/O	DESCRIPTION
	bq24230	bq24232		
TS	1	1	I	External NTC Thermistor Input. Connect the TS input to the NTC thermistor in the battery pack. TS monitors a 10-kΩ NTC thermistor. For applications that do not utilize the TS function, connect a 10-kΩ fixed resistor from TS to VSS to maintain a valid voltage level on TS.
BAT	2,3	2, 3	I/O	Charger Power Stage Output and Battery Voltage Sense Input. Connect BAT to the positive terminal of the battery. Bypass BAT to VSS with a 4.7-μF to 47-μF ceramic capacitor.
$\overline{\text{CE}}$	4	4	I	Charge Enable Active-Low Input. Connect $\overline{\text{CE}}$ to a high logic level to disable battery charging. OUT is active and battery supplement mode is still available. Connect $\overline{\text{CE}}$ to a low logic level to enable the battery charger. $\overline{\text{CE}}$ is internally pulled down with ~285 kΩ. Do not leave $\overline{\text{CE}}$ unconnected to ensure proper operation.
EN2	5	5	I	Input Current Limit Configuration Inputs. Use EN1 and EN2 control the maximum input current and enable USB compliance. See Table 1 for the description of the operation states. EN1 and EN2 are internally pulled down with ~285 kΩ. Do not leave EN1 or EN2 unconnected to ensure proper operation.
EN1	6	6	I	
$\overline{\text{PGOOD}}$	7	7	O	Open-drain Power Good Status Indication Output. $\overline{\text{PGOOD}}$ pulls to VSS when a valid input source is detected. $\overline{\text{PGOOD}}$ is high-impedance when the input power is not within specified limits. Connect $\overline{\text{PGOOD}}$ to the desired logic voltage rail using a 1-kΩ – 100-kΩ resistor, or use with an LED for visual indication.
VSS	8	8	–	Ground. Connect to the thermal pad and to the ground rail of the circuit.
$\overline{\text{CHG}}$	9	9	O	Open-Drain Charging Status Indication Output. $\overline{\text{CHG}}$ pulls to VSS when the battery is charging. $\overline{\text{CHG}}$ is high impedance when charging is complete and when charger is disabled.
OUT	10,11	10, 11	O	System Supply Output. OUT provides a regulated output when the input is below the OVP threshold and above the regulation voltage. When the input is out of the operation range, OUT is connected to V _{BAT} . Connect OUT to the system load. Bypass OUT to VSS with a 4.7-μF to 47-μF ceramic capacitor.
ILIM	12	12	I	Adjustable Current Limit Programming Input. Connect a 3.1-kΩ to 7.8-kΩ resistor from ILIM to VSS to program the maximum input current (EN2=1, EN1=0). The input current includes the system load and the battery charge current. Leaving ILIM unconnected disables all charging. In USB100/500 mode (EN2 = 0, EN1= 0/1), ILIM can be left floating.

Pin Functions (continued)

NAME	PIN		I/O	DESCRIPTION
	NUMBER			
	bq24230	bq24232		
IN	13	13	I	Input Power Connection. Connect IN to the connected to external DC supply (AC adapter or USB port). The input operating range is 4.35 V to 6.6 V. The input can accept voltages up to 26 V without damage but operation is suspended. Connect bypass capacitor 1 μ F to 10 μ F to VSS.
TMR	14	14	I	Timer Programming Input. TMR controls the precharge and fast-charge safety timers. Connect TMR to VSS to disable all safety timers. Connect a 18-k Ω to 72-k Ω resistor between TMR and VSS to program the timers a desired length. Leave TMR unconnected to set the timers to the 5-hour fast charge and 30-minute precharge default timer values.
TD	15	-	I	Termination Dsable Input. Connect TD high to disable charger termination. Connect TD to VSS to enable charger termination. TD is checked during start-up only and cannot be changed during operation. See the TD section in this data sheet for a description of the behavior when termination is disabled. TD is internally pulled down to VSS with \sim 285 k Ω . Do not leave TD unconnected to ensure proper operation.
ITERM	-	15	I	Termination Current Programming Input. Connect a 0- Ω to 15-k Ω resistor from ITERM to VSS to program the termination current. Leave ITERM unconnected to set the termination current to the internal default 10% threshold.
ISET	16	16	I/O	Fast-Charge Current Programming Input. Connect a 1.8-k Ω to 36-k Ω resistor from ISET to VSS to program the fast-charge current level. Charging is disabled if ISET is left unconnected. While charging, the voltage at ISET reflects the actual charging current and can be used to monitor charge current. See the Charge Current Translator section for more details.
Thermal Pad			–	An internal electrical connection exists between the exposed thermal pad and the VSS pin of the device. The thermal pad must be connected to the same potential as the VSS pin on the printed-circuit board. Do not use the thermal pad as the primary ground input for the device. The VSS pin must be connected to ground at all times.

Table 1. EN1/EN2 Settings

EN2	EN1	Maximum Input Current Into IN Pin
0	0	100 mA. USB100 mode
0	1	500 mA. USB500 mode
1	0	Set by an external resistor from ILIM to VSS
1	1	Standby (USB suspend mode)

7 Specifications

7.1 Absolute Maximum Ratings

over operating free-air temperature range (unless otherwise noted) ⁽¹⁾

			MIN	MAX	UNIT
V _I	Input voltage	IN (with respect to VSS)	-0.3	28	V
		OUT (with respect to VSS)	-0.3	7	
		BAT (with respect to VSS)	-0.3	5	
		EN1, EN2, \overline{CE} , TS, ISET, \overline{PGOOD} , \overline{CHG} , ILIM, TMR, TD, ITERM (with respect to VSS)	-0.3	7	
I _I	Input current	IN		600	mA
I _O	Output current (continuous)	OUT		1700	mA
		BAT (Discharge mode)		1700	
	Output sink current	\overline{CHG} , \overline{PGOOD}		15	mA
T _J	Junction temperature		-40	150	°C
T _{stg}	Storage temperature		-65	150	

(1) Stresses beyond those listed under *Absolute Maximum Ratings* may cause permanent damage to the device. These are stress ratings only, which do not imply functional operation of the device at these or any other conditions beyond those indicated under *Recommended Operating Conditions*. Exposure to absolute-maximum-rated conditions for extended periods may affect device reliability. All voltage values are with respect to the network ground terminal unless otherwise noted.

7.2 ESD Ratings

			VALUE	UNIT
V _(ESD)	Electrostatic discharge	Human body model (HBM), per ANSI/ESDA/JEDEC JS-001, all pins ⁽¹⁾	±1000	V
		Charged device model (CDM), per JEDEC specification JESD22-C101, all pins ⁽²⁾	±250	

(1) JEDEC document JEP155 states that 500-V HBM allows safe manufacturing with a standard ESD control process.

(2) JEDEC document JEP157 states that 250-V CDM allows safe manufacturing with a standard ESD control process.

7.3 Recommended Operating Conditions

over operating free-air temperature range (unless otherwise noted)

			MIN	MAX	UNIT	
V _I	IN voltage range		4.35	26	V	
		IN operating voltage range	bq24230	4.35	6.4	V
			bq24232	4.35	10.2	
I _{IN}	Input current, IN pin			500	mA	
I _{OUT}	Current, OUT pin			1500	mA	
I _{BAT}	Current, BAT pin (discharging)			1500	mA	
I _{CHG}	Current, BAT pin (charging)			500	mA	
T _J	Junction temperature		-40	125	°C	
R _{ILIM}	Maximum input current programming resistor		3.1	7.8	kΩ	
R _{ISET}	Fast-charge current programming resistor		1.8	36	kΩ	
R _{TMR}	Timer programming resistor		18	72	kΩ	
R _{ITERM}	Termination programming resistor	bq24232	0	15	kΩ	

7.4 Thermal Information

THERMAL METRIC ⁽¹⁾		bq24230	bq24232	UNIT
		RGT	RGT	
		16 PINS	16 PINS	
$R_{\theta JA}$	Junction-to-ambient thermal resistance	44.5	44.5	°C/W
$R_{\theta JC(top)}$	Junction-to-case (top) thermal resistance	54.2	54.2	°C/W
$R_{\theta JB}$	Junction-to-board thermal resistance	17.2	17.2	°C/W
Ψ_{JT}	Junction-to-top characterization parameter	1.0	1.0	°C/W
Ψ_{JB}	Junction-to-board characterization parameter	17.1	17.1	°C/W
$R_{\theta JC(bot)}$	Junction-to-case (bottom) thermal resistance	3.8	3.8	°C/W

(1) For more information about traditional and new thermal metrics, see the *IC Package Thermal Metrics* application report, [SPRA953](#).

7.5 Electrical Characteristics

over operating free-air temperature range (unless otherwise noted)

PARAMETER	TEST CONDITIONS	MIN	TYP	MAX	UNIT	
INPUT						
UVLO	Undervoltage lockout	$V_{IN}: 0\text{ V} \rightarrow 4\text{ V}$	3.2	3.3	3.4	V
$V_{hys(UVLO)}$	Hysteresis on UVLO	$V_{IN}: 4\text{ V} \rightarrow 0\text{ V}$	200		300	mV
$V_{IN(DT)}$	Input power detection threshold	Input power detected when $V_{IN} > V_{BAT} + V_{IN(DT)}$ $V_{BAT} = 3.6\text{ V}$, $V_{IN}: 3.5\text{ V} \rightarrow 4\text{ V}$	55	80	130	mV
$V_{hys(INDT)}$	Hysteresis on $V_{IN(DT)}$	$V_{BAT} = 3.6\text{ V}$, $V_{IN}: 4\text{ V} \rightarrow 3.5\text{ V}$	20			mV
V_{OVP}	Input overvoltage protection threshold	(230) $V_{IN}: 5\text{ V} \rightarrow 7\text{ V}$	6.4	6.6	6.8	V
		(232) $V_{IN}: 5\text{ V} \rightarrow 11\text{ V}$	10.2	10.5	10.8	
$V_{hys(OVP)}$	Hysteresis on OVP	(230) $V_{IN}: 7\text{ V} \rightarrow 5\text{ V}$		110		mV
		(232) $V_{IN}: 11\text{ V} \rightarrow 5\text{ V}$		175		
ILIM, TEST ISET SHORT CIRCUIT						
I_{SC}	Current source	$V_{IN} > UVLO$ and $V_{IN} > V_{BAT} + V_{IN(DT)}$		1.3		mA
V_{SC}		$V_{IN} > UVLO$ and $V_{IN} > V_{BAT} + V_{IN(DT)}$		520		mV
QUIESCENT CURRENT						
$I_{BAT(PDWN)}$	Sleep current into BAT pin	$\overline{CE} = LO$ or HI , input power not detected, no load on OUT pin, $T_J = 85^\circ\text{C}$			6.5	μA
$I_{IN(STDBY)}$	Standby current into IN pin	$EN1 = HI$, $EN2 = HI$, $V_{IN} = 6\text{ V}$, $T_J = 85^\circ\text{C}$			50	μA
		$EN1 = HI$, $EN2 = HI$, $V_{IN} = 10\text{ V}$, $T_J = 85^\circ\text{C}$			200	
I_{CC}	Active supply current, IN pin	$\overline{CE} = LO$, $V_{IN} = 6\text{ V}$, no load on OUT pin, $V_{BAT} > V_{BAT(REG)}$, $(EN1, EN2) \neq (HI, HI)$			1.5	mA

Electrical Characteristics (continued)

over operating free-air temperature range (unless otherwise noted)

PARAMETER		TEST CONDITIONS	MIN	TYP	MAX	UNIT
POWER PATH						
$V_{DO(IN-OUT)}$	$V_{IN} - V_{OUT}$	$V_{IN} = 4.3 \text{ V}$, $I_{IN} = 500 \text{ mA}$, $V_{BAT} = 4.2 \text{ V}$		150.0	237.5	mV
$V_{DO(BAT-OUT)}$	$V_{BAT} - V_{OUT}$	$I_{OUT} = 500 \text{ mA}$, $V_{IN} = 0 \text{ V}$, $V_{BAT} > 3 \text{ V}$			62.5	mV
$V_{O(REG)}$	OUT pin voltage regulation	$V_{IN} > V_{OUT} + V_{DO (IN-OUT)}$	4.3	4.4	4.5	V
I_{INmax}	Maximum input current	EN1 = LO, EN2 = LO	90	95	100	mA
		EN1 = HI, EN2 = LO	450	475	500	
		EN2 = HI, EN1 = LO	K_{ILIM}/R_{ILIM}			A
K_{ILIM}	Maximum input current factor	$I_{LIM} = 200 \text{ mA to } 500 \text{ mA}$	1380	1530	1680	AΩ
I_{INmax}	Programmable input current limit range	EN2 = HI, EN1 = LO, $R_{ILIM} = 2.75 \text{ k}\Omega \text{ to } 8.4 \text{ k}\Omega$	200		500	mA
V_{IN-DPM}	Input voltage threshold when input current is reduced	EN2 = LO, EN1 = X	4.35	4.50	4.63	V
V_{DPPM}	Output voltage threshold when charging current is reduced		$V_{O(REG)} - 180 \text{ mV}$	$V_{O(REG)} - 100 \text{ mV}$	$V_{O(REG)} - 30 \text{ mV}$	V
V_{BSUP1}	Enter battery supplement mode	$V_{BAT} = 3.6 \text{ V}$, $R_{ILIM} = 1.5 \text{ k}\Omega$, $R_{LOAD} = 10 \Omega \rightarrow 2 \Omega$		$V_{OUT} \leq V_{BAT} - 40 \text{ mV}$		V
V_{BSUP2}	Exit battery supplement mode	$V_{BAT} = 3.6 \text{ V}$, $R_{ILIM} = 1.5 \text{ k}\Omega$, $R_{LOAD} = 2 \Omega \rightarrow 10 \Omega$		$V_{OUT} \geq V_{BAT} - 20 \text{ mV}$		V
$V_{O(SC1)}$	Output short-circuit detection threshold, power-on	$V_{IN} > UVLO$ and $V_{IN} > V_{BAT} + V_{IN(DT)}$	0.8	0.9	1	V
$V_{O(SC2)}$	Output short-circuit detection threshold, supplement mode $V_{BAT} - V_{OUT} > V_{O(SC2)}$ indicates short circuit	$V_{IN} > UVLO$ and $V_{IN} > V_{BAT} + V_{IN(DT)}$	200	250	300	mV

Electrical Characteristics (continued)

over operating free-air temperature range (unless otherwise noted)

PARAMETER		TEST CONDITIONS	MIN	TYP	MAX	UNIT
BATTERY CHARGER						
$I_{BAT(SC)}$	Source current for BAT pin short-circuit detection	$V_{BAT} = 1.5\text{ V}$	4	7.5	11	mA
$V_{BAT(SC)}$	BAT pin short-circuit detection threshold	V_{BAT} rising	1.6	1.8	2	V
$V_{BAT(REG)}$	Battery charge voltage		4.16	4.20	4.23	V
V_{LOWV}	Precharge to fast-charge transition threshold	$V_{IN} > UVLO$ and $V_{IN} > V_{BAT} + V_{IN(DT)}$	2.9	3	3.1	V
I_{CHG}	Battery fast-charge current range	$V_{BAT(REG)} > V_{BAT} > V_{LOWV}$, $V_{IN} = 5\text{ V}$, $\overline{CE} = LO$, $EN1 = LO$, $EN2 = HI$	25		500	mA
	Battery fast-charge current	$\overline{CE} = LO$, $EN1 = LO$, $EN2 = HI$, $V_{BAT} > V_{LOWV}$, $V_{IN} = 5\text{ V}$, $I_{INmax} > I_{CHG}$, no load on OUT pin, thermal loop and DPM loop not active		K_{ISET}/R_{ISET}		A
K_{ISET}	Fast-charge current factor	$25\text{ mA} \geq I_{CHG} \geq 500\text{ mA}$	797	870	975	AΩ
$K_{IPRECHG}$	Precharge current factor	$2.5\text{ mA} \geq I_{PRECHG} \geq 30\text{ mA}$	70	88	106	AΩ
I_{TERM}	Termination comparator threshold for termination detection	$\overline{CE} = LO$, $(EN1, EN2) \neq (LO, LO)$, $V_{BAT} > V_{RCH}$, $t < t_{MAXCH}$, $V_{IN} = 5\text{ V}$, DPM loop and thermal loop not active	$0.09 \cdot I_{CHG}$	$0.1 \cdot I_{CHG}$	$0.11 \cdot I_{CHG}$	A
		$\overline{CE} = LO$, $(EN1, EN2) = (LO, LO)$, $V_{BAT} > V_{RCH}$, $t < t_{MAXCH}$, $V_{IN} = 5\text{ V}$, DPM loop and thermal loop not active	$0.027 \cdot I_{CHG}$	$0.033 \cdot I_{CHG}$	$0.040 \cdot I_{CHG}$	A
I_{TERM}	Termination current threshold factor (bq24232)	$I_{TERM} = 0\%$ to 50% of I_{CHG}		$K_{I_{TERM}} \cdot R_{I_{TERM}}/R_{I_{SET}}$		A
$I_{BIAS(I_{TERM})}$	Current for external termination-setting resistor		72	75	78	μA
$K_{I_{TERM}}$	K factor for termination detection threshold (externally set) (bq24232)	$\overline{CE} = LO$, $(EN1, EN2) \neq (LO, LO)$, $V_{BAT} > V_{RCH}$, $t < t_{MAXCH}$, $V_{IN} = 5\text{ V}$, DPM loop and thermal loop not active	0.024	0.030	0.036	A
		$\overline{CE} = LO$, $(EN1, EN2) = (LO, LO)$, $V_{BAT} > V_{RCH}$, $t < t_{MAXCH}$, $V_{IN} = 5\text{ V}$, DPM loop and thermal loop not active	0.009	0.010	0.011	A
$I_{BIAS(I_{TERM})}$	Current for external termination_setting resistor (bq24232)		72	75	78	μA
V_{RCH}	Recharge detection threshold	$V_{IN} > UVLO$ and $V_{IN} > V_{BAT} + V_{IN(DT)}$	$V_{BAT(REG)} - 140\text{ mV}$	$V_{BAT(REG)} - 100\text{ mV}$	$V_{BAT(REG)} - 60\text{ mV}$	V
$I_{BAT(DET)}$	Sink current for battery detection	$V_{BAT} = 2.5\text{ V}$	5	7.5	10	mA
BATTERY-PACK NTC MONITOR⁽¹⁾						
I_{NTC}	NTC bias current	$V_{IN} > UVLO$ and $V_{IN} > V_{BAT} + V_{IN(DT)}$	72	75	78	μA
V_{HOT}	High-temperature trip point	Battery charging, V_{TS} Falling	270	300	330	mV
$V_{HYS(HOT)}$	Hysteresis on high trip point	Battery charging, V_{TS} Rising from V_{HOT}		30		mV
V_{COLD}	Low-temperature trip point	Battery charging, V_{TS} Rising	2000	2100	2200	mV
$V_{HYS(COLD)}$	Hysteresis on low trip point	Battery charging, V_{TS} Falling from V_{COLD}		300		mV
$V_{DIS(TS)}$	TS function disable threshold	TS unconnected		$V_{IN} - 200\text{ mV}$		V
THERMAL REGULATION						
$T_{J(REG)}$	Temperature regulation limit			125		°C
$T_{J(OFF)}$	Thermal shutdown temperature	T_J rising		155		°C
$T_{J(OFF-HYS)}$	Thermal shutdown hysteresis			20		°C

(1) These numbers set trip points of 0°C and 50°C while charging, with 3°C hysteresis on the trip points, with a Vishay Type 2 curve NTC with an R25 of 10 kΩ.

Electrical Characteristics (continued)

over operating free-air temperature range (unless otherwise noted)

PARAMETER	TEST CONDITIONS	MIN	TYP	MAX	UNIT
LOGIC LEVELS ON EN1, EN2, \overline{CE}, TD					
V_{IL}	Logic LOW input voltage	0		0.4	V
V_{IH}	Logic HIGH input voltage	1.4		6.0	V
I_{iL}	Input sink current	$V_{iL} = 0$ V		1	μ A
I_{iH}	Input source current	$V_{iH} = 1.4$ V		10	μ A
LOGIC LEVELS ON \overline{PGOOD}, \overline{CHG}					
V_{OL}	Output LOW voltage	$I_{SINK} = 5$ mA		0.4	V

7.6 Timing Requirements

over operating free-air temperature range (unless otherwise noted)

PARAMETER	TEST CONDITIONS	MIN	TYP	MAX	UNIT	
INPUT						
$t_{DGL(PGOOD)}$	Deglintch time, input power detected status	Time measured from V_{IN} : 0 V \rightarrow 5-V 1- μ s rise time to $\overline{PGOOD} = LO$		2	ms	
$t_{DGL(OVP)}$	Input overvoltage blanking time		50		μ s	
$t_{REC(OVP)}$	Input overvoltage recovery time	Time measured from V_{IN} : 11 V \rightarrow 5-V 1- μ s fall time to $\overline{PGOOD} = LO$		2	ms	
POWER PATH						
$t_{DGL(SC2)}$	Deglintch time, supplement mode short circuit		250		μ s	
$t_{REC(SC2)}$	Recovery time, supplement mode short circuit		60		ms	
BATTERY CHARGER						
$t_{DGL1(LOWV)}$	Deglintch time on precharge to fast-charge transition		25		ms	
$t_{DGL2(LOWV)}$	Deglintch time on fast-charge to precharge transition		25		ms	
$t_{DGL(TERM)}$	Deglintch time, termination detected		25		ms	
$t_{DGL(RCH)}$	Deglintch time, recharge threshold detected		62.5		ms	
$t_{DGL(NO-IN)}$	Delay time, input power loss to charger turnoff	$V_{BAT} = 3.6$ V. Time measured from V_{IN} : 5 V \rightarrow 3 V 1- μ s fall time		20	ms	
BATTERY CHARGING TIMERS						
t_{PRECHG}	Precharge safety timer value	TMR = floating	1440	1800	2160	s
t_{MAXCHG}	Charge safety timer value	TMR = floating	14400	18000	21600	s
t_{PRECHG}	Precharge safety timer value	$18 \text{ k}\Omega < R_{TMR} < 72 \text{ k}\Omega$	$R_{TMR} \times K_{TMR}$		s	
t_{MAXCHG}	Charge safety timer value	$18 \text{ k}\Omega < R_{TMR} < 72 \text{ k}\Omega$	$10 \times R_{TMR} \times K_{TMR}$		s	
K_{TMR}	Timer factor		36	48	60	s/k Ω
BATTERY-PACK NTC MONITOR ⁽¹⁾						
$t_{DGL(TS)}$	Deglintch time, pack temperature fault detection	Battery charging, V_{TS} Falling		50	ms	

(1) These numbers set trip points of 0°C and 50°C while charging, with 3°C hysteresis on the trip points, with a Vishay Type 2 curve NTC with an R25 of 10 k Ω .

7.7 Typical Characteristics

Typical Application Circuit, EN1=0, EN2=1, $T_A=25^\circ\text{C}$, unless otherwise noted.

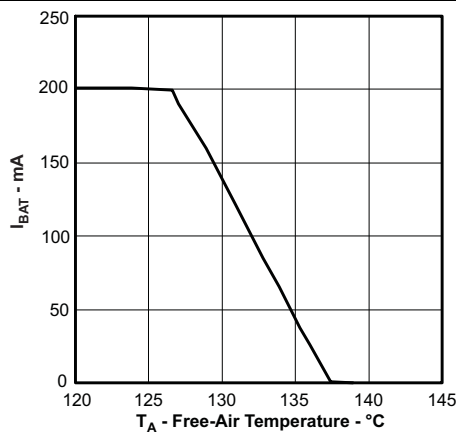
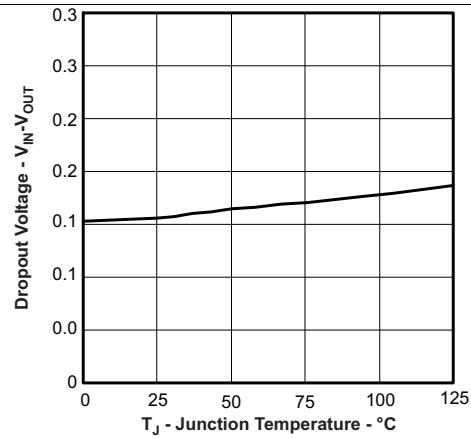
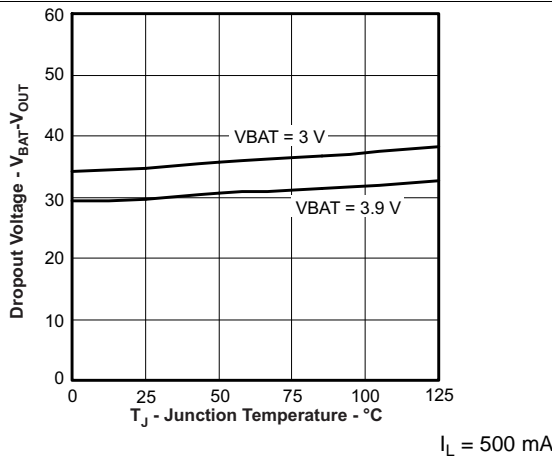

Figure 1. Thermal Regulation



$I_L = 500 \text{ mA}$

Figure 2. Dropout Voltage vs Temperature



$I_L = 500 \text{ mA}$

Figure 3. Dropout Voltage vs Temperature

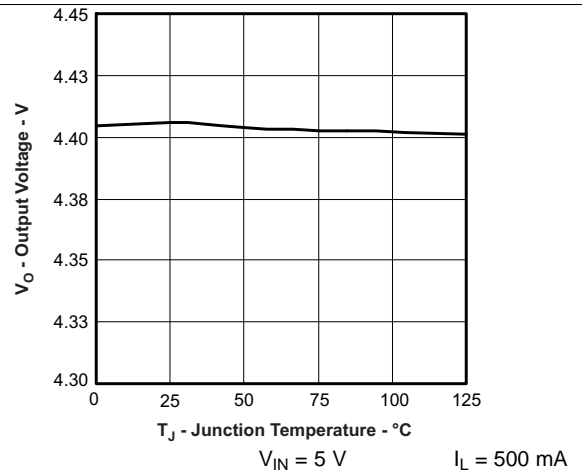

$V_{IN} = 5 \text{ V}$

$I_L = 500 \text{ mA}$

Figure 4. Output Regulation Voltage vs Temperature

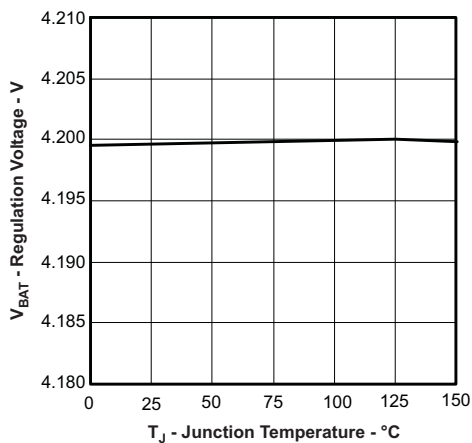
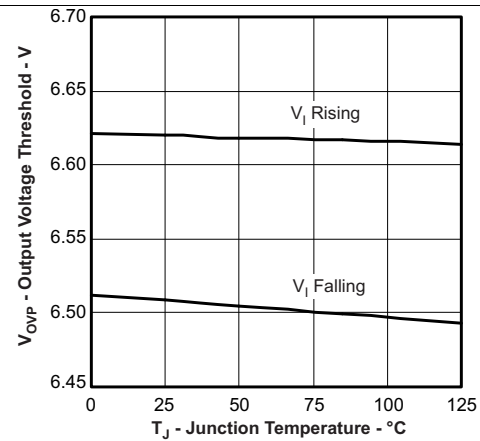

Figure 5. Battery Regulation Voltage vs Temperature



6.6 V

Figure 6. Overvoltage Protection Threshold vs Temperature
bq24230

Typical Characteristics (continued)

Typical Application Circuit, EN1=0, EN2=1, T_A=25°C, unless otherwise noted.

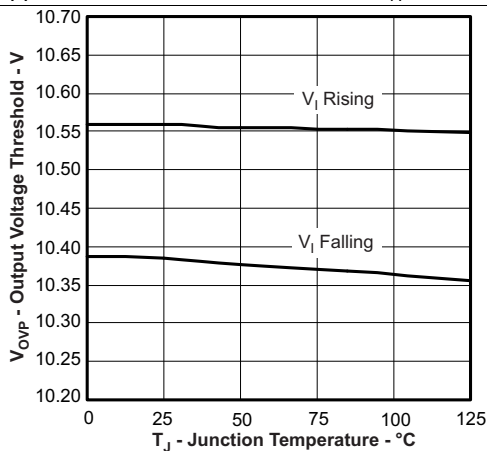

10.5 V

Figure 7. Overvoltage Protection Threshold vs Temperature bq24232

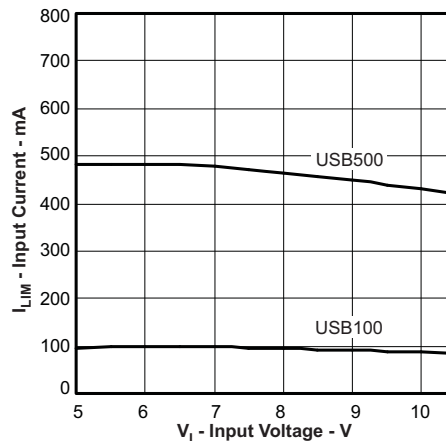

Figure 8. Input Current Limit Threshold vs Input Voltage

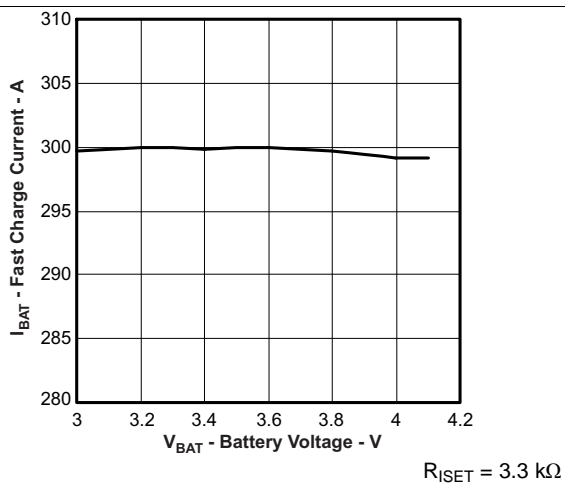

Figure 9. Fast-Charge Current vs Battery Voltage

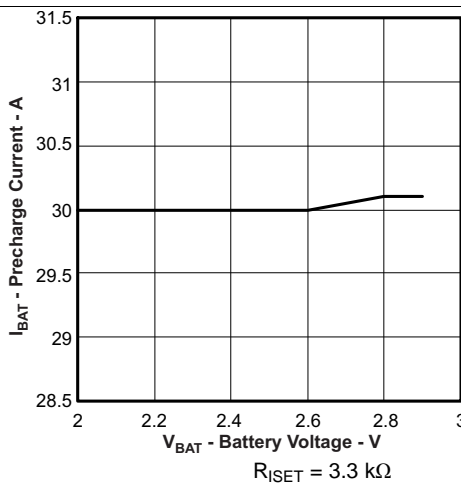

Figure 10. Precharge Current vs Battery Voltage

8 Detailed Description

8.1 Overview

The bq2423x devices are integrated Li-ion linear chargers and system power-path management devices targeted at space-limited portable applications. The device powers the system while simultaneously and independently charging the battery. This feature reduces the number of charge and discharge cycles on the battery, allows for proper charge termination, and enables the system to run with a defective or absent battery pack. It also allows instant system turnon even with a totally discharged battery. The input power source for charging the battery and running the system can be an AC adapter or a USB port. The devices feature dynamic power-path management (DPPM), which shares the source current between the system and battery charging and automatically reduces the charging current if the system load increases. When charging from a USB port, the input dynamic power management (V_{IN} -DPM) circuit reduces the input current limit if the input voltage falls below a threshold, preventing the USB port from crashing. The power-path architecture also permits the battery to supplement the system current requirements when the adapter cannot deliver the peak system currents.

8.2 Functional Block Diagram

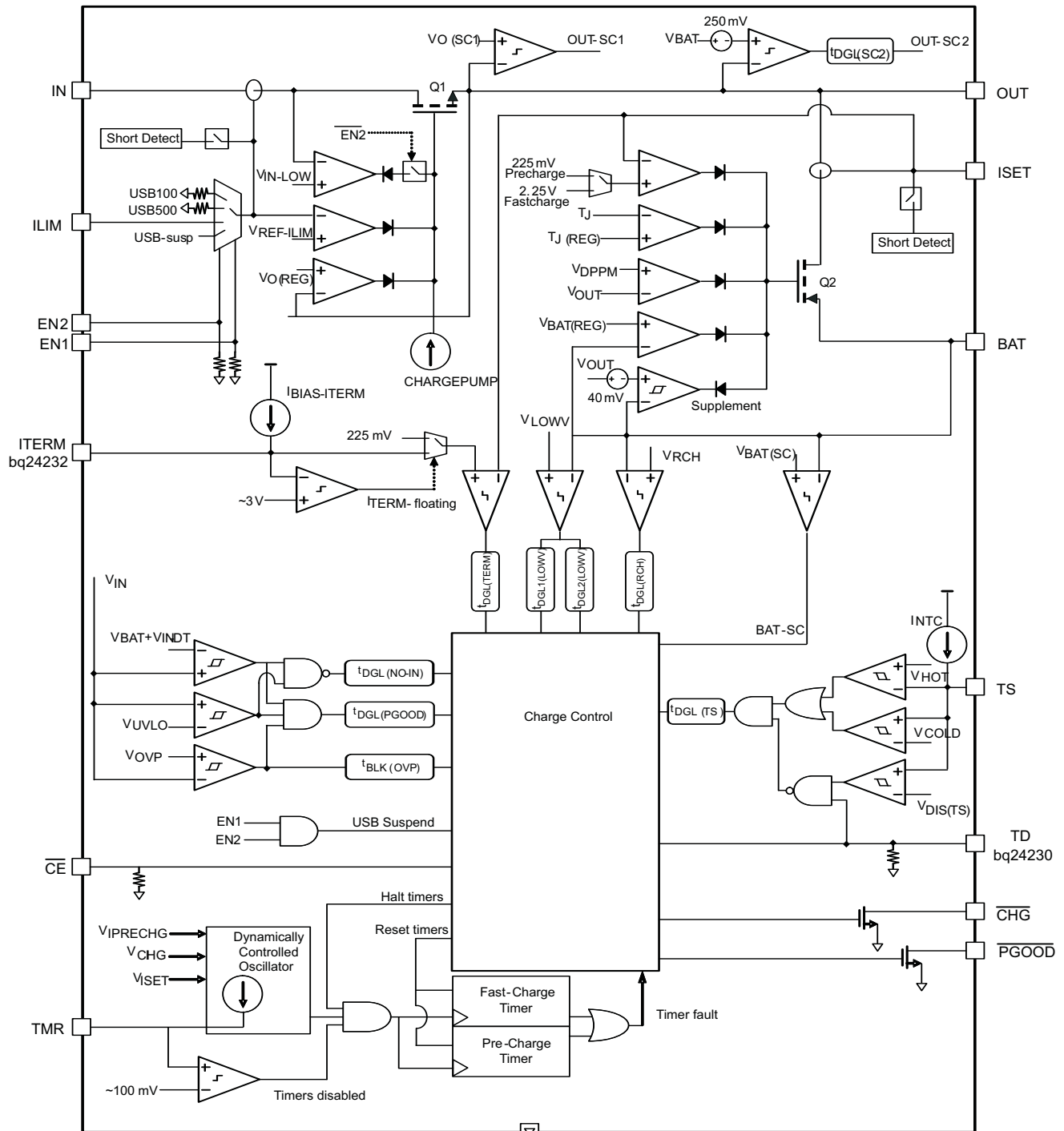

8.3 Feature Description

8.3.1 Undervoltage Lockout

The bq2423x family remains in power-down mode when the input voltage at the IN pin is below the undervoltage lockout (UVLO) threshold.

During the power-down mode, the host commands at the control inputs ($\overline{\text{CE}}$, EN1 and EN2) are ignored. The Q1 FET connected between IN and OUT pins is off, and the status outputs $\overline{\text{CHG}}$ and $\overline{\text{PGOOD}}$ are high impedance. The Q2 FET that connects BAT to OUT is ON. During power-down mode, the $V_{\text{OUT(SC2)}}$ circuitry is active and monitors for overload conditions on OUT.

8.3.2 Power On

When V_{IN} exceeds the UVLO threshold, the bq2423x powers up. While V_{IN} is below $V_{\text{BAT}} + V_{\text{IN(DT)}}$, the host commands at the control inputs ($\overline{\text{CE}}$, EN1, and EN2) are ignored. The Q1 FET connected between IN and OUT pins is off, and the status outputs $\overline{\text{CHG}}$ and $\overline{\text{PGOOD}}$ are high impedance. The Q2 FET that connects BAT to OUT is ON. During this mode, the $V_{\text{OUT(SC2)}}$ circuitry is active and monitors for overload conditions on OUT.

When V_{IN} rises above $V_{\text{BAT}} + V_{\text{IN(DT)}}$, $\overline{\text{PGOOD}}$ is low to indicate that the valid power status and the $\overline{\text{CE}}$, EN1, and EN2 inputs are read. The device enters standby mode whenever (EN1, EN2) = (1, 1) or if an input overvoltage condition occurs. In standby mode, Q1 is OFF and Q2 is ON. During standby mode, the $V_{\text{OUT(SC2)}}$ circuitry is active and monitors for overload conditions on OUT.

When the input voltage at IN is within the valid range: $V_{\text{IN}} > \text{UVLO}$ **AND** $V_{\text{IN}} > V_{\text{BAT}} + V_{\text{IN(DT)}}$ **AND** $V_{\text{IN}} < V_{\text{OVP}}$, and the EN1 and EN2 pins indicate that the USB suspend mode is not enabled [(EN1, EN2) \neq (HI, HI)], all internal timers and other circuit blocks are activated. The device checks for short circuits at the ISET and ILIM pins. If no short conditions exists, the device switches on the input FET Q1 with a 100-mA current limit to check for a short circuit at OUT. If V_{OUT} rises above V_{SC} , the FET Q1 switches to the current-limit threshold set by EN1, EN2, and R_{ILIM} and the device enters normal operation where the system is powered by the input source (Q1 is on), and the device continuously monitors the status of $\overline{\text{CE}}$, EN1, and EN2 as well as the input voltage conditions.

Feature Description (continued)

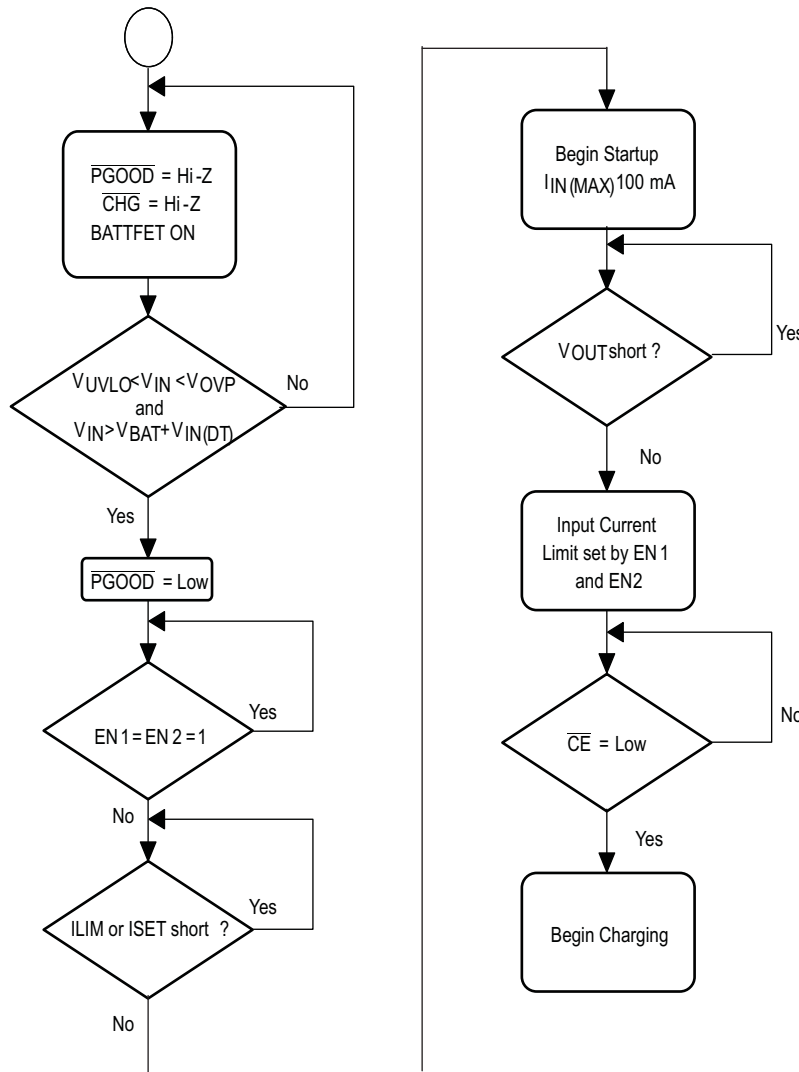

Figure 11. Start-Up Flow Diagram

8.3.3 Power-Path Management

The bq2423x features an OUT output that powers the external load connected to the battery. This output is active whenever a source is connected to IN or BAT. The following sections discuss the behavior of OUT with a source connected to IN to charge the battery and a battery source only.

8.3.3.1 Input Source Connected – Adapter or USB

With a source connected, the power-path management circuitry of the bq2423x monitors the input current continuously. The OUT output is regulated to a fixed voltage ($V_{O(REG)}$). The current into IN is shared between charging the battery and powering the system load at OUT. The bq2423x has internal selectable current limits of 100 mA (USB100) and 500 mA (USB500) for charging from USB ports, as well as a resistor-programmable input current limit. See Table 1 for EN1, EN2 setting.

The bq2423x is USB-IF compliant for the inrush current testing. The USB spec allows up to 10 μ F to be hard-started, which establishes 50 μ F as the maximum inrush charge value when exceeding 100 mA. The input current limit for the bq2423x prevents the input current from exceeding this limit, even with system capacitances greater than 10 μ F. Note that the input capacitance to the device must be selected small enough to prevent a violation (<10 μ F), as this current is not limited.

Feature Description (continued)

The input current limit selection is controlled by the state of the EN1 and EN2 pins as shown in [Table 1](#). When using the resistor-programmable current limit, the input current limit is set by the value of the resistor connected from the ILIM pin to VSS and is given by the [Equation 1](#):

$$I_{IN-MAX} = K_{ILIM}/R_{ILIM} \quad (1)$$

The input current limit is adjustable up to 500 mA. The valid resistor range is 2.75 kΩ to 8.4 kΩ.

When the IN source is connected, priority is given to the system load. The DPPM and Battery Supplement modes are used to maintain the system load. [Figure 12](#) illustrates examples of the DPPM and supplement modes. These modes are explained in detail in the following sections.

8.3.3.1.1 Input Voltage Dynamic Power Management, (V_{IN_DPM})

The bq2423x uses the V_{IN_DPM} mode for operation from current-limited sources (including USB ports). The input voltage is monitored and compared to the V_{IN_DPM} threshold (nominally ~ 4.5V). If the adaptor input voltage begins to collapse, the input current limit is reduced to prevent the supply voltage from falling further. This prevents the bq2423x from crashing the external power source in case of a current-limited supply regardless of the input current limit setting (USB100, USB500, or external resistor-set ILIM mode)..

8.3.3.1.2 Dynamic Power Path Management (DPPM)

When the sum of the charging (BAT) and system (OUT) currents exceeds the preset maximum input current (programmed with EN1, EN2, and ILIM pins), the voltage at the OUT pin decreases. Once the voltage on the OUT pin falls to the VDPPM limit, the bq2423x enters DPPM mode. In this mode, the charging current is reduced and power to the system is prioritized. Battery termination is disabled and the charge timer period is extended while in DPPM mode, because the charging current is less than the programmed value.

8.3.3.1.3 Battery Supplement Mode

If the system load current demand exceeds the input current limit, even with charging current reduced to zero, the OUT voltage continues to drop. When the OUT pin voltage drops below V_{BSUP1} , the partially charged battery supplements the external power source to provide current to the system. When the OUT pin voltage increases above V_{BSUP2} the device exits battery supplement mode and all system current is drawn from the external power source.

During supplement mode, the battery supplement current is not regulated; however, a short-circuit protection circuit is built in. If during battery supplement mode, the voltage at OUT drops 250 mV below the BAT voltage, the OUT output is turned off if the overload exists after $t_{DGL(SC2)}$. The short-circuit recovery timer then starts counting. After $t_{REC(SC2)}$, OUT turns on and attempts to restart. If the short circuit remains, OUT is turned off and the counter restarts. Battery termination is disabled while in supplement mode.

Feature Description (continued)

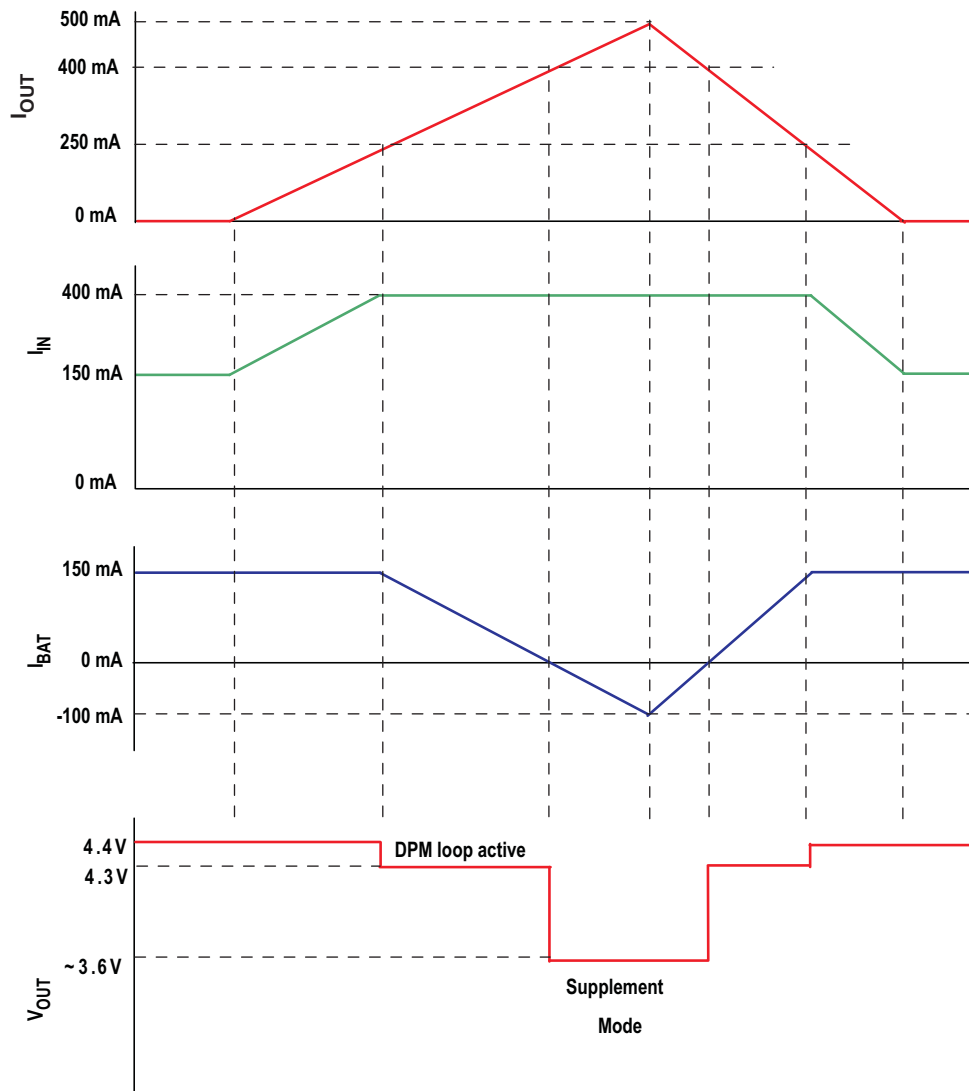

Figure 12. bq2423x DPM And Battery Supplement Modes
($V_{OREG} = 4.4\text{ V}$, $V_{BAT} = 3.6\text{ V}$, $I_{LIM} = 400\text{ mA}$, $I_{CHG} = 150\text{ mA}$)

8.3.3.2 Input Source Not Connected

When no source is connected to the IN input, OUT is powered strictly from the battery. During this mode, the current into OUT is unregulated, similar to *Battery Supplement Mode*; however, the short-circuit circuitry is active. If the OUT voltage falls below the BAT voltage by 250 mV for longer than $t_{DGL(SC2)}$, OUT is turned off. The short-circuit recovery timer then starts counting. After $t_{REC(SC2)}$, OUT turns on and attempts to restart. If the short-circuit remains, OUT is turned off and the counter restarts. This ON/OFF cycle continues until the overload condition is removed.

Feature Description (continued)

8.3.4 Thermal Regulation and Thermal Shutdown

The bq2423x contain a thermal regulation loop that monitors the die temperature. If the die temperature exceeds $T_{J(REG)}$, the device automatically reduces the charging current to prevent the die temperature from increasing further. In some cases, the die temperature continues to rise despite the operation of the thermal loop, particularly under high VIN and heavy OUT system load conditions. Under these conditions, if the die temperature increases to $T_{J(OFF)}$, the input FET Q1 is turned OFF. FET Q2 is turned ON to ensure that the battery still powers the load on OUT. Once the device die temperature cools by $T_{J(OFF-HYS)}$, the input FET Q1 is turned on and the device returns to thermal regulation. Continuous overtemperature conditions result in a hiccup mode. Safety timers are slowed proportionally to the charge current in thermal regulation. Battery termination is disabled during thermal regulation and thermal shutdown.

Note that this feature monitors the die temperature of the bq2423x. This is not synonymous with ambient temperature. Self-heating exists due to the power dissipated in the IC because of the linear nature of the battery charging algorithm and the LDO mode for OUT.

A modified charge cycle with the thermal loop active is shown in Figure 13:

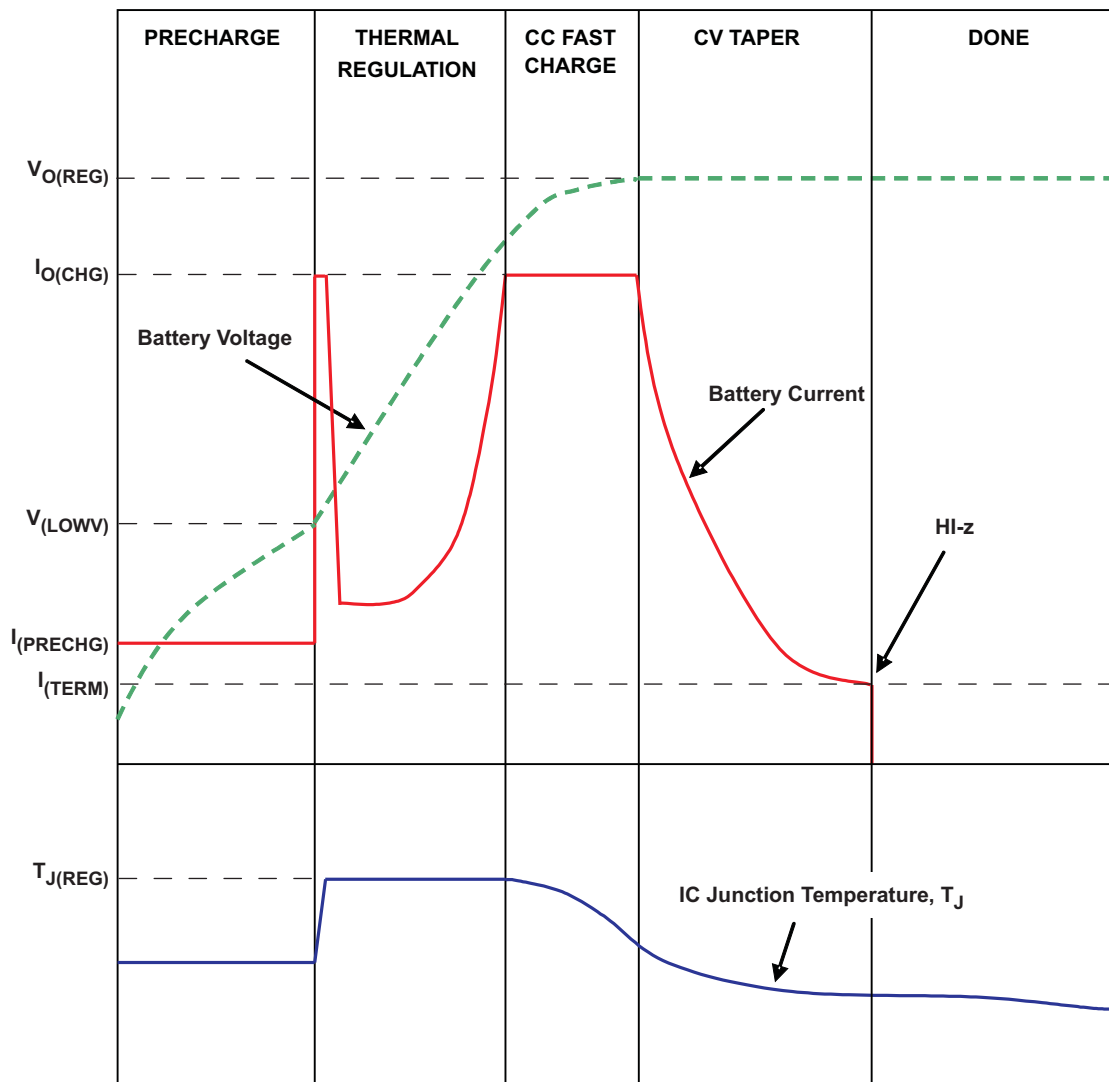

Figure 13. Modified Charge Cycle

Feature Description (continued)

8.3.5 Battery Pack Temperature Monitoring

The bq2423x features an external battery pack temperature monitoring input. The TS input connects to the NTC resistor in the battery pack to monitor battery temperature and prevent dangerous over-temperature conditions. Using the basic connection as shown in the [Typical Application Circuit](#) example on page 1, a nominal range of 0° to 50°C is achieved using a standard 103AT – 2 type thermistor ($\beta = 3435$) with no additional external components.

During charging, INTC is sourced to TS and the voltage at TS is continuously monitored. If, at any time, the voltage at TS is outside of the operating range (V_{COLD} to V_{HOT}), charging is suspended. The timers maintain their values but suspend counting. When the voltage measured at TS returns to within the operation window, charging is resumed and the timers continue counting. When charging is suspended due to a battery pack temperature fault, the CHG pin remains low and continues to indicate charging.

For the bq24230, battery pack temperature sensing is disabled when termination is disabled (TD = High) and the voltage at TS is greater than $V_{DIS(TS)}$. The battery pack temperature monitoring is disabled in all devices by connecting a fixed 10-k Ω resistor from TS to VSS so that the voltage at the TS pin is always within the voltage range to permit charging.

8.3.5.1 Modifying / Extending the Allowable Temperature Range for Charging

The nominal temperature range to allow charging is 0°C to 50°C when using a typical 103AT-2 type thermistor. However, the user can increase the range by adding two external resistors. See [Figure 14](#) for the circuit. The values for R_s and R_p are calculated using the following equations:

$$R_s = \frac{-(R_{TH} + R_{TC}) \pm \sqrt{\left((R_{TH} + R_{TC})^2 - 4 \left\{ R_{TH} \times R_{TC} + \frac{V_H \times V_C}{(V_H - V_C) \times I_{TS}} \times (R_{TC} - R_{TH}) \right\} \right)}}{2} \quad (2)$$

$$R_p = \frac{V_H \times (R_{TH} + R_s)}{I_{TS} \times (R_{TH} + R_s) - V_H} \quad (3)$$

Where:

- R_{TH} : Thermistor Hot Trip Value found in thermistor data sheet
- R_{TC} : Thermistor Cold Trip Value found in thermistor data sheet
- V_H : Hot Trip Threshold of the IC = 0.3 V nominal
- V_C : Cold Trip Threshold of the IC = 2.1 V nominal
- I_{TS} : Output Current Bias of the IC = 75 μ A nominal
- NTC Thermistor Semitec 103AT-2 Type or equivalent

[Table 2](#) provides examples of the thermistor resistance at different temperatures and suggested typical R_s and R_p values, using 1% tolerance resistors that can extend the allowable temperature range beyond the standard 0°C – to – 50° C window.

Table 2. Example Thermistor Resistance and Suggested Typical R_s and R_p Values

COLD TEMP RESISTANCE AND TRIP THRESHOLD; Ω (°C)	HOT TEMP RESISTANCE AND TRIP THRESHOLD; Ω (°C)	EXTERNAL BIAS RESISTOR, R_s (Ω)	EXTERNAL BIAS RESISTOR, R_p (Ω)
28000 (–0.6)	4000 (51)	0	∞
28480 (–1)	3536 (55)	487	845000
28480 (–1)	3021 (60)	1000	549000
33890 (–5)	4026 (51)	76.8	158000
33890 (–5)	3536 (55)	576	150000
33890 (–5)	3021 (60)	1100	140000

RHOT and RCOLD are the thermistor resistance at the desired hot and cold temperatures, respectively. Note that the temperature window cannot be tightened more using the thermistor connected to TS, it can only be extended.

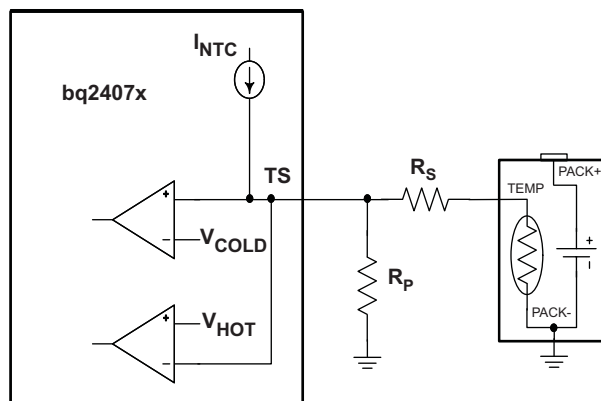

Figure 14. Extended TS Temperature Thresholds

8.4 Device Functional Modes

8.4.1 Battery Charging

Set \overline{CE} low to initiate battery charging. First, the device checks for a short circuit on the BAT pin by sourcing $I_{BAT(SC)}$ to the battery and monitoring the voltage. When the BAT voltage exceeds $V_{BAT(SC)}$, the battery charging continues. The battery is charged in three phases: conditioning precharge, constant-current fast charge (current regulation), and a constant-voltage tapering (voltage regulation). In all charge phases, an internal control loop monitors the IC junction temperature and reduces the charge current if an internal temperature threshold is exceeded.

Figure 15 illustrates a normal Li-ion charge cycle using the bq2423x:

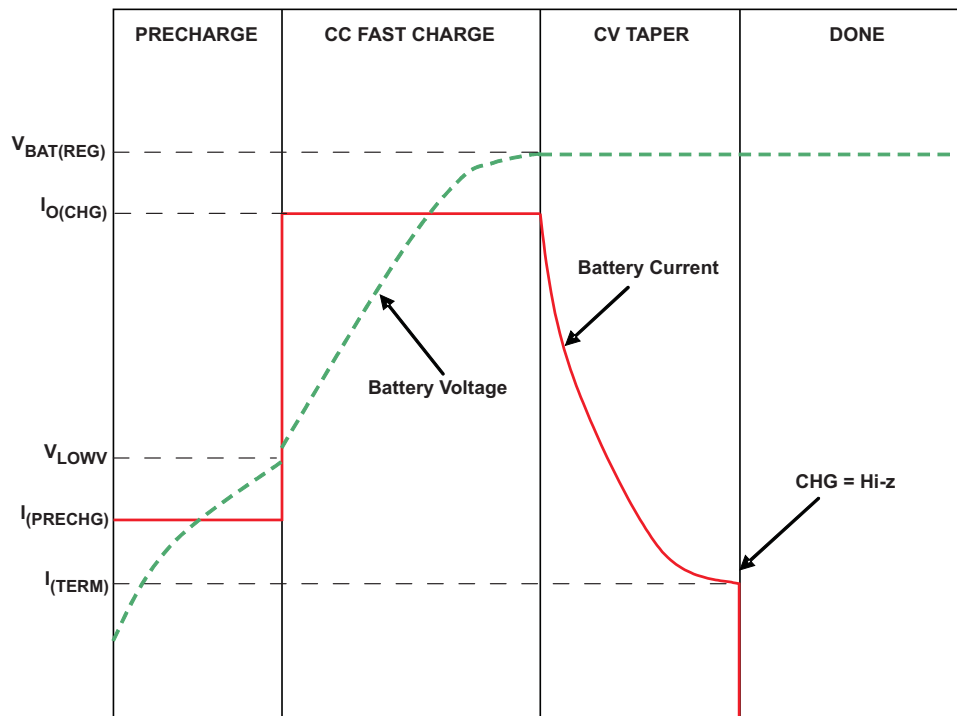

Figure 15. Normal Li-Ion Charge Cycle

Device Functional Modes (continued)

In the precharge phase, the battery is charged with the precharge current (I_{PRECHG}). Once the battery voltage crosses the V_{LOWV} threshold, the battery is charged with the fast-charge current (I_{CHG}). As the battery voltage reaches $V_{\text{BAT(REG)}}$, the battery is held at a constant voltage of $V_{\text{BAT(REG)}}$ and the charge current tapers off as the battery approaches full charge. When the battery current reaches I_{TERM} , the CHG pin indicates *charging done* by going high impedance.

Note that termination detection is disabled whenever the charge rate is reduced because of the actions of the thermal loop, the DPPM loop, or the $V_{\text{IN(LOW)}}$ loop.

The value of the fast-charge current is set by the resistor connected from the ISET pin to VSS, and is given by the equation:

$$I_{\text{CHG}} = K_{\text{ISET}}/R_{\text{ISET}} \quad (4)$$

The charge current limit is adjustable from 25 mA to 500 mA. The valid resistor range is 1.8 k Ω to 36 k Ω . Note that if I_{CHG} is programmed as greater than the input current limit, the battery does not charge at the rate of I_{CHG} , but at the slower rate of $I_{\text{IN(MAX)}}$ (minus the load current on the OUT pin, if any). In this case, the charger timers are proportionately slowed down.

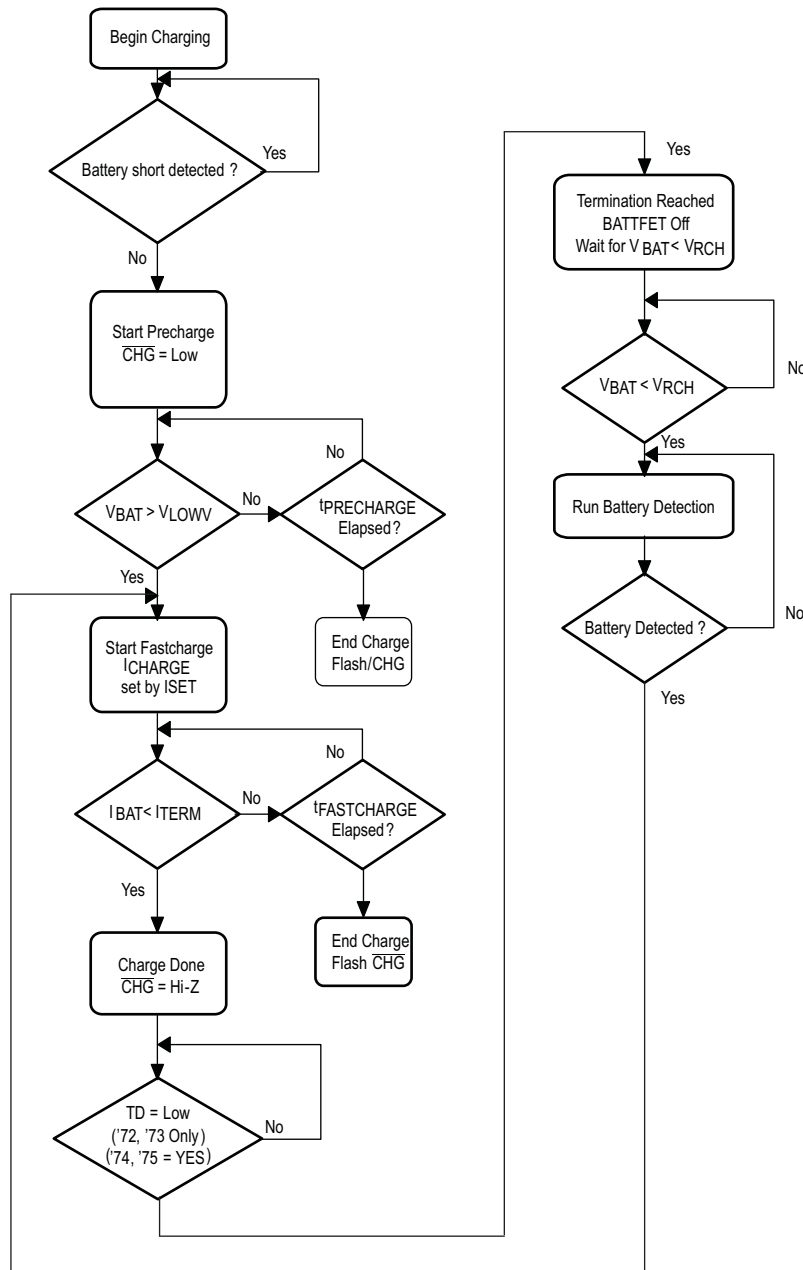
Device Functional Modes (continued)

Figure 16. Battery Charging Flow Diagram
8.4.1.1 Charge Current Translator

When the charger is enabled, internal circuits generate a current proportional to the charge current at the ISET input. The current out of ISET is 1/400 ($\pm 10\%$) of the charge current. This current, when applied to the external charge current programming resistor, R_{ISET} , generates an analog voltage that can be monitored by an external host to calculate the current sourced from BAT.

$$V_{ISET} = (I_{CHARGE} / 400) \times R_{ISET} \quad (5)$$

Device Functional Modes (continued)

8.4.1.2 Battery Detection and Recharge

The bq2423x automatically detects if a battery is connected or removed. Once a charge cycle is complete, the battery voltage is monitored. When the battery voltage falls below V_{RCH} , the battery detection routine is run. The detection routine first applies $I_{BAT(DET)}$ for t_{DET} to see if V_{BAT} drops below V_{LOWV} . If not, it indicates that the battery is still connected, but has discharged. If \overline{CE} is low, the charger is turned on again to top off the battery. During this recharge cycle, the \overline{CHG} output remains high-impedance as recharge cycles are not indicated by the \overline{CHG} pin. If the BAT voltage falls below V_{LOWV} during the battery detection test, it indicates that the battery has been removed or the protector is open. Next, the precharge current is applied for t_{DET} to close the protector if possible. If the battery voltage does not rise above V_{RCH} , it indicates that the protector is closed, or a battery has been inserted, and a new charge cycle begins. If the voltage rises above V_{RCH} , the battery is determined missing and the detection routine continues. The battery detection runs until a battery is detected.

8.4.1.3 Termination Disable (TD Input, bq24230)

The bq24230 contains a TD input that allows termination to be enabled/disabled. Connect TD to a logic high to disable charge termination. When termination is disabled, the device goes through the precharge, fast-charge, and CV phases, then remains in the CV phase. During the CV phase, the charger maintains the output voltage at BAT equal to $V_{BAT(REG)}$, and charging current does not terminate. BAT sources currents up to I_{CHG} or I_{IN-MAX} , whichever is less. Battery detection is not performed. The \overline{CHG} output is high impedance once the current falls below I_{TERM} and does not go low until the input power or \overline{CE} are toggled. When termination is disabled, the precharge and fast-charge safety timers are also disabled. Battery pack temperature sensing (TS pin functionality) is also disabled if the TD pin is high and the TS pin is unconnected.

8.4.1.4 Adjustable Termination Threshold (ITERM Input, bq24232)

The termination current threshold for the bq24232 is user-programmable. Set the termination current by connecting a resistor from ITERM to VSS. For USB100, mode (EN1 = EN2 = VSS), the termination current value is calculated as:

$$I_{TERM} = 0.01 \times R_{ITERM} / R_{ISET} \quad (6)$$

In the other input current limit modes (EN1 \neq EN2), the termination current value is calculated as:

$$I_{TERM} = 0.03 \times R_{ITERM} / R_{ISET} \quad (7)$$

The termination current is programmable up to 50% of the fast-charge current. The R_{ITERM} resistor must be less than 15 k Ω . Leave ITERM unconnected to select the default internally set termination current.

8.4.1.5 Dynamic Charge Timers (TMR Input)

The bq2423x devices contain internal safety timers for the precharge and fast-charge phases to prevent potential damage to the battery and the system. The timers begin at the start of the respective charge cycles. The timer values are programmed by connecting a resistor from TMR to VSS. The resistor value is calculated using the following equation:

$$t_{PRECHG} = K_{TMR} \times R_{TMR} \quad (8)$$

$$t_{MAXCHG} = 10 \times K_{TMR} \times R_{TMR} \quad (9)$$

Leave TMR unconnected to select the internal default timers. Disable the timers by connecting TMR to VSS. Reset the timers by toggling CE pin.

Note that timers are suspended when the device is in thermal shutdown, and the timers are slowed proportionally to the charge current when the device enters thermal regulation. For the bq24230, the timers are disabled when TD is connected to a high logic level.

During the fast-charge phase, several events increase the timer durations.

1. The system load current activates the DPPM loop which reduces the available charging current
2. The input current is reduced because the input voltage has fallen to $V_{IN(LOW)}$
3. The device has entered thermal regulation because the IC junction temperature has exceeded $T_{J(REG)}$

During each of these events, the internal timers are slowed down proportionately to the reduction in charging current. For example, if the charging current is reduced by half for two minutes, the timer clock is reduced to half the frequency and the counter counts half as fast resulting in only one minute of counted time.

Device Functional Modes (continued)

8.4.1.6 Status Indicators ($\overline{\text{PGOOD}}$, $\overline{\text{CHG}}$)

The bq2423x contains two open-drain outputs that signal its status. The $\overline{\text{PGOOD}}$ output signals when a valid input source is connected. $\overline{\text{PGOOD}}$ is low when $(V_{\text{BAT}} + V_{\text{IN(DT)}}) < V_{\text{IN}} < V_{\text{OVP}}$. When the input voltage is outside of this range, $\overline{\text{PGOOD}}$ is high impedance.

The $\overline{\text{CHG}}$ output signals when a new charge cycle is initiated. After a charge cycle is initiated, $\overline{\text{CHG}}$ goes low once the battery is above the short-circuit threshold. $\overline{\text{CHG}}$ goes high impedance once the charge current falls below I_{TERM} . $\overline{\text{CHG}}$ remains high impedance until the input power is removed and reconnected or the $\overline{\text{CE}}$ pin is toggled. It does not signal subsequent recharge cycles.

Table 3. $\overline{\text{PGOOD}}$ Status Indicator

Input State	$\overline{\text{PGOOD}}$ Output
$V_{\text{IN}} < V_{\text{UVLO}}$	Hi impedance
$V_{\text{UVLO}} < V_{\text{IN}} < V_{\text{IN(DT)}} + V_{\text{BAT}}$	Hi impedance
$V_{\text{IN(DT)}} + V_{\text{BAT}} < V_{\text{IN}} < V_{\text{OVP}}$	Low
$V_{\text{IN}} > V_{\text{OVP}}$	Hi impedance

Table 4. $\overline{\text{CHG}}$ Status Indicator

Charge State	$\overline{\text{CHG}}$ Output
Charging	Low (first charge cycle)
Charging terminated	Hi impedance until power or $\overline{\text{CE}}$ is toggled
Recharging after termination	Hi impedance
Charging suspended by thermal loop	Low (first charge cycle)
Safety timers expired	Flashing at 2Hz
IC disabled or no valid input power	Hi impedance

8.4.1.6.1 Timer Fault

If the precharge timer expires before the battery voltage reaches V_{LOWV} , the bq2423x indicates a fault condition. Additionally, if the battery current does not fall to I_{TERM} before the fast-charge timer expires, a fault is indicated. The $\overline{\text{CHG}}$ output flashes at approximately 2 Hz to indicate a fault condition.

8.4.2 Explanation of Deglitch Times and Comparator Hysteresis

Figures not to scale

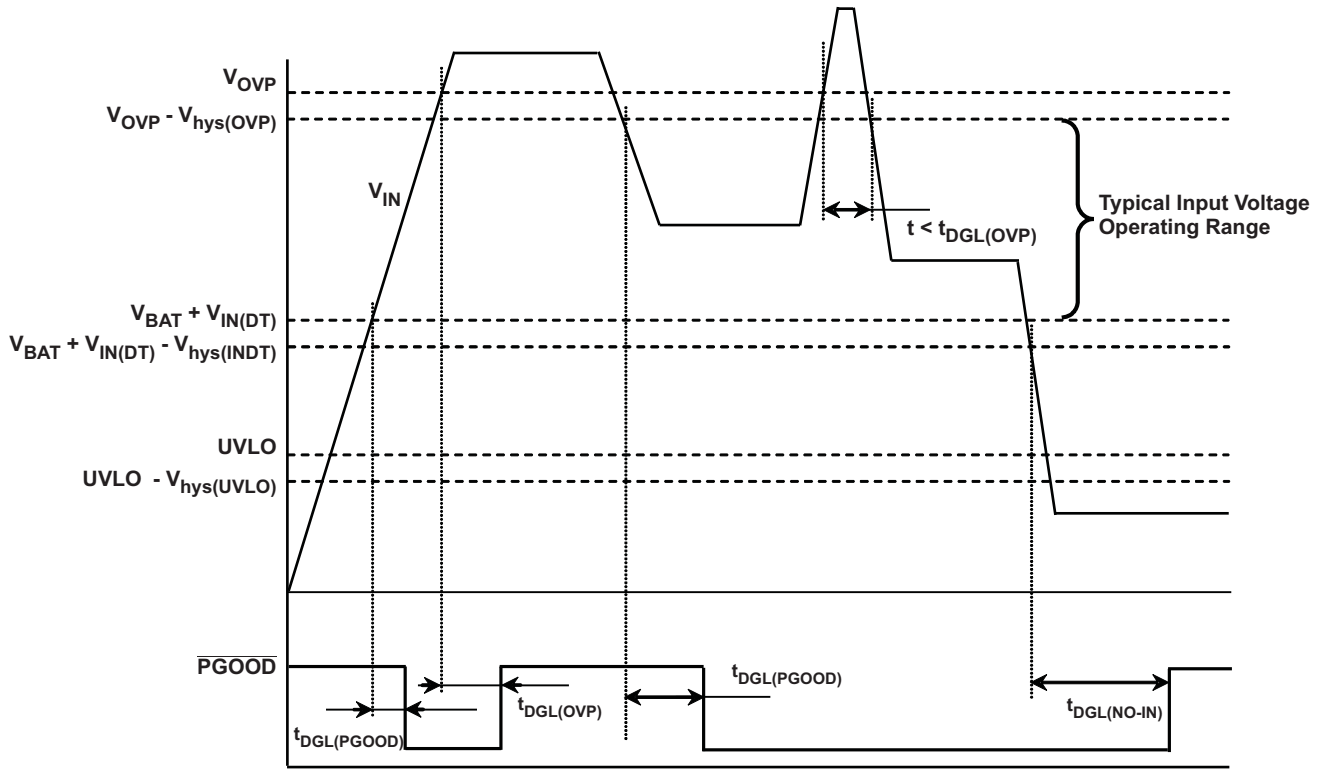

Figure 17. Power Up, Power Down

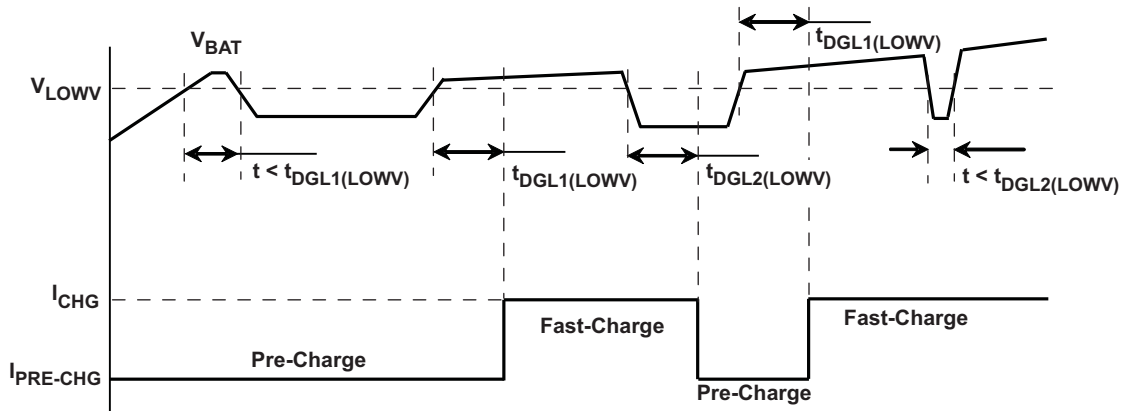

Figure 18. Pre- To Fast-Charge, Fast- To Precharge Transition – $T_{DGL1(LOWV)}$, $T_{DGL2(LOWV)}$

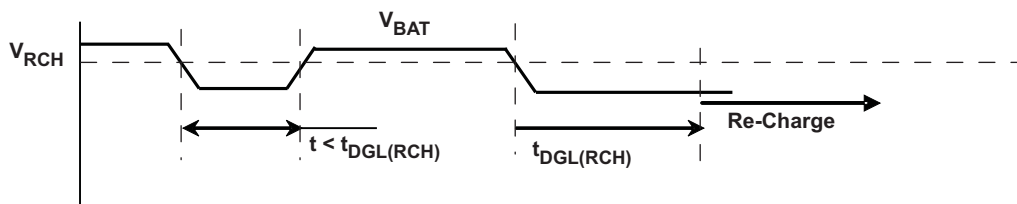

Figure 19. Recharge – $T_{DGL(RCH)}$

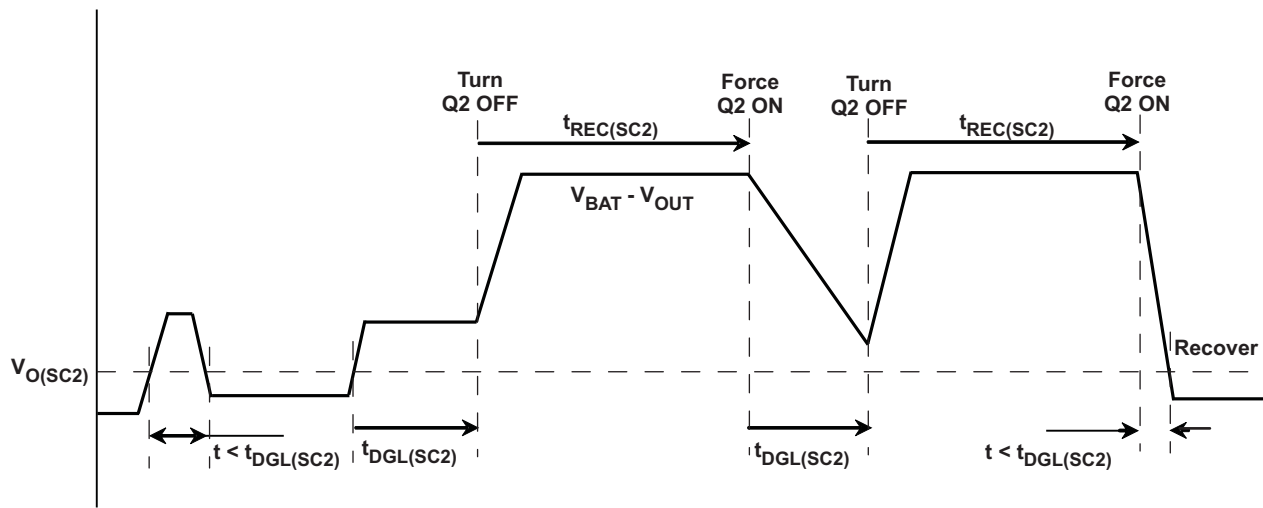

Figure 20. Out Short-Circuit – Supplement Mode

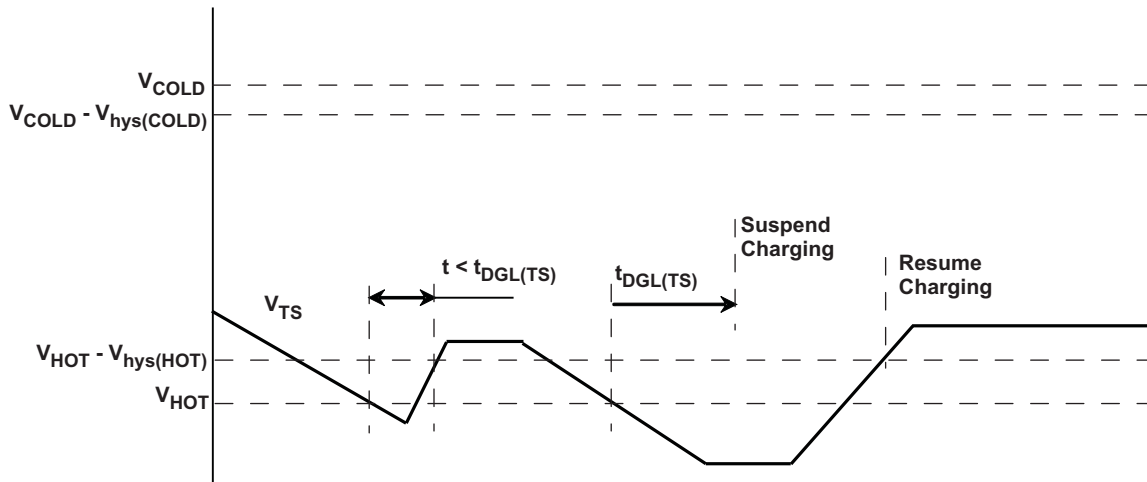

Figure 21. Battery Pack Temperature Sensing – TS Pin. Battery Temperature Increasing

9 Application and Implementation

NOTE

Information in the following applications sections is not part of the TI component specification, and TI does not warrant its accuracy or completeness. TI's customers are responsible for determining suitability of components for their purposes. Customers should validate and test their design implementation to confirm system functionality.

9.1 Application Information

The bq2423x devices power the system while simultaneously and independently charging the battery. The input power source for charging the battery and running the system can be an AC adapter or a USB port. The devices feature dynamic power-path management (DPPM), which shares the source current between the system and battery charging and automatically reduces the charging current if the system load increases. When charging from a USB port, the input dynamic power management (V_{IN} -DPM) circuit reduces the input current limit if the input voltage falls below a threshold, preventing the USB port from crashing. The power-path architecture also permits the battery to supplement the system current requirements when the adapter cannot deliver the peak system currents.

The bq2423x can be configured as host controlled for selecting different input current limits based on the input source connected; or, as a fully stand-alone device for applications that do not support multiple types of input sources.

9.2 Typical Applications

9.2.1 Using The bq24232 In A Stand-Alone Charger Application

See [Figure 22](#) for the Design Example Schematic.

$V_{IN} = V_{UVLO}$ to V_{OVP} , $I_{FASTCHG} = 200$ mA, $I_{IN(MAX)} = 500$ mA, 25-mA Termination Current, ISET mode (EN1=0, EN2=1), Battery Temperature Charge Range 0°C to 50°C, 7.5-hour Fast Charge Safety Timer.

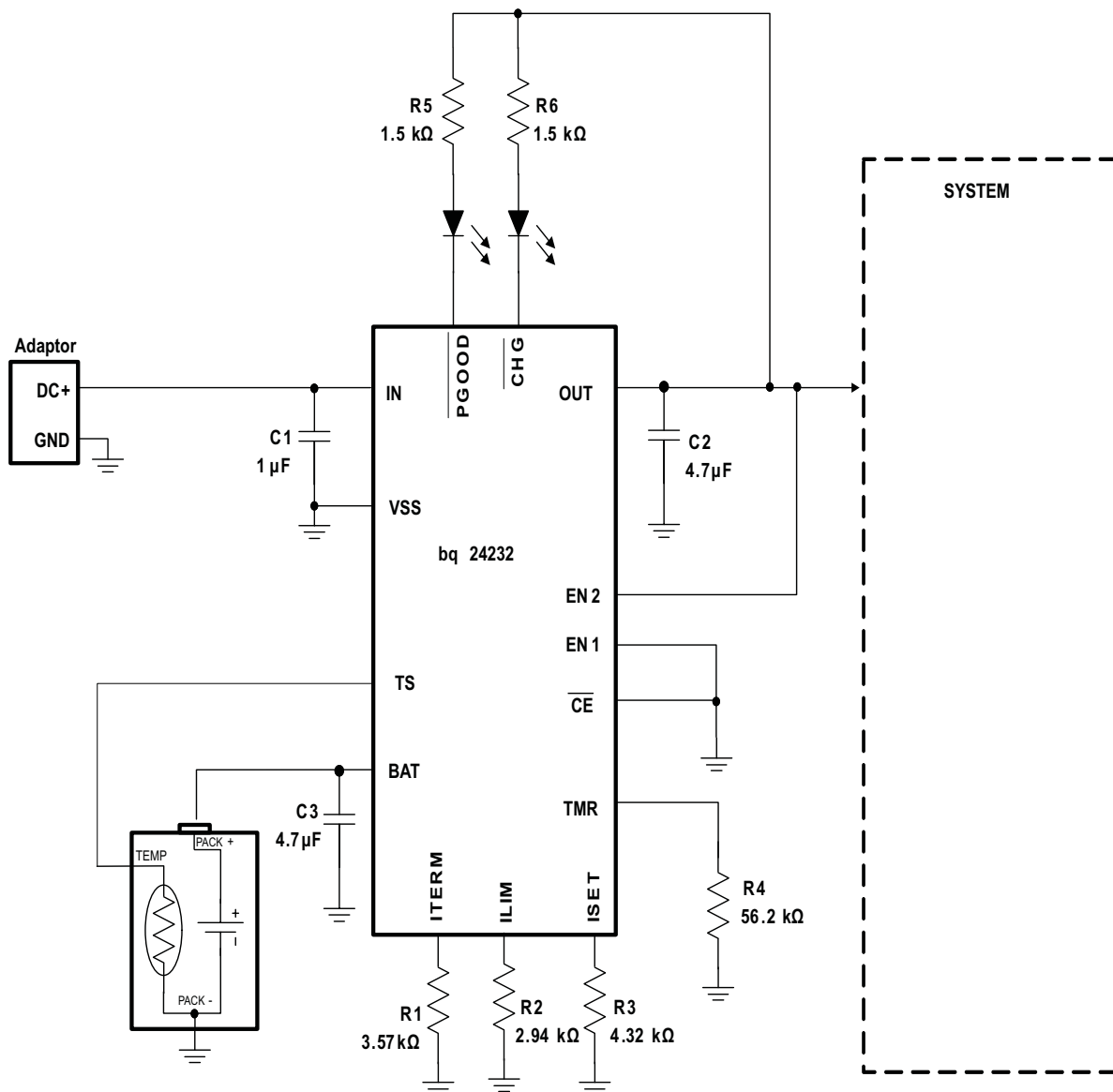
Typical Applications (continued)

Figure 22. Using The bq24232 in a Stand-Alone Charger Application
9.2.1.1 Design Requirements

- Supply voltage = 5 V
- Fast-charge current of approximately 200 mA; ISET - pin 16
- Input Current Limit = 500 mA; ILIM - pin 12
- Termination Current = 25 mA - pin 15 (bq24232)
- Safety timer duration, Fast charge = 7.5 hours; TMR – pin 14
- TS – Battery Temperature Sense = 10 kΩ NTC (103AT-2)

Typical Applications (continued)

9.2.1.2 Detailed Design Procedure

9.2.1.2.1 Calculations

9.2.1.2.1.1 Program The Fast-Charge Current (ISET):

$$R_{ISET} = K_{ISET} / I_{CHG}$$

$K_{ISET} = 870 \text{ A}\Omega$ from the electrical characteristics table.

$$R_{ISET} = 870 \text{ A}\Omega / 0.2 \text{ A} = 4.35 \text{ k}\Omega$$

Select the closest standard value, which for this case is 4.32 k Ω . Connect this resistor between ISET (pin 16) and V_{SS} .

9.2.1.2.1.2 Program The Input Current Limit (ILIM)

$$R_{ILIM} = K_{ILIM} / I_{L_MAX}$$

$K_{ILIM} = 1530 \text{ A}\Omega$ from the electrical characteristics table.

$$R_{ISET} = 1530 \text{ A}\Omega / 0.5 \text{ A} = 3.06 \text{ k}\Omega$$

Select the closest standard value, which for this case is 3.06 k Ω . Connect this resistor between ILIM (pin 12) and V_{SS} .

9.2.1.2.1.3 Program The Termination Current Threshold (ITERM, bq24232)

$$R_{ITERM} = R_{ISET} \times I_{TERM} / K_{ITERM}$$

$K_{ITERM} = 0.03 \text{ A}$ from electrical characteristics table

$$R_{ITERM} = 4.32 \text{ k}\Omega \times 0.025 \text{ A} / 0.03 \text{ A} = 3.6 \text{ k}\Omega$$

Select the closest standard value, which for this case is 3.57 k Ω . Connect this resistor between ITERM (pin 15) and V_{SS} .

9.2.1.2.1.4 Program 7.5-hour Fast-Charge Safety Timer (TMR)

$$R_{TMR} = t_{MAXCHG} / (10 \times K_{TMR})$$

$K_{TMR} = 48 \text{ s/k}\Omega$ from the electrical characteristics table.

$$R_{TMR} = (7.5 \text{ hr} \times 3600 \text{ s/hr}) / (10 \times 48 \text{ s/k}\Omega) = 56.25 \text{ k}\Omega$$

Select the closest standard value, which for this case is 56.2 k Ω . Connect this resistor between TMR (pin 2) and V_{SS} .

9.2.1.2.2 TS Function

Use a 10-k Ω NTC thermistor in the battery pack (103AT). To disable the temperature sense function, use a fixed 10-k Ω resistor between the TS (pin 1) and V_{SS} . Pay close attention to the linearity of the chosen NTC so that it provides the desired hot and cold turnoff thresholds.

9.2.1.2.3 $\overline{\text{CHG}}$ and $\overline{\text{PGOOD}}$

LED Status: connect a 1.5-k Ω resistor in series with a LED between OUT and $\overline{\text{CHG}}$ and OUT and $\overline{\text{PGOOD}}$.

Processor Monitoring Status: connect a pullup resistor (approximately 100 k Ω) between the processor's power rail and $\overline{\text{CHG}}$ and $\overline{\text{PGOOD}}$.

Typical Applications (continued)

9.2.1.2.4 Selecting In, Out, and BAT Pin Capacitors

In most applications, all that is needed is a high-frequency decoupling capacitor (ceramic) on the power pin, input, output, and battery pins. Using the values shown on the application diagram is recommended. After evaluation of these voltage signals with real system operational conditions, the user can determine if capacitance values can be adjusted toward the minimum recommended values (dc load application) or higher values for fast, high-amplitude, pulsed load applications. Note, if the application is designed with high input voltage sources (bad adapters or wrong adapters), the capacitor needs to be rated appropriately. Ceramic capacitors are tested to 2x their rated values so a 16-V capacitor may be adequate for a 30-V transient (verify the tested rating with capacitor manufacturer).

9.2.1.3 Application Curves

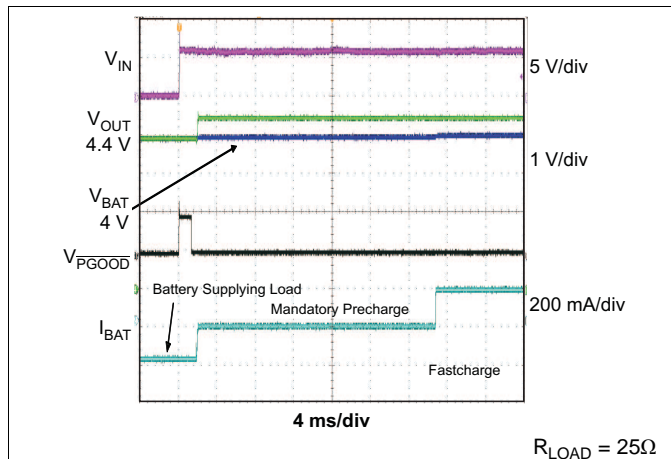

Figure 23. Adapter Plug-In With Battery Connected

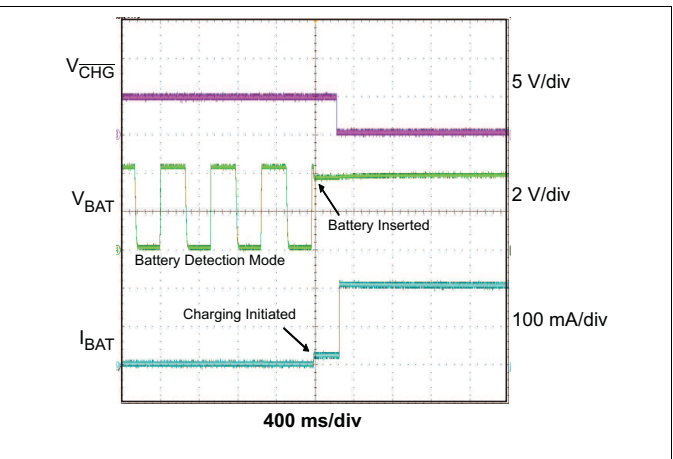

Figure 24. Battery Detection -- Insertion

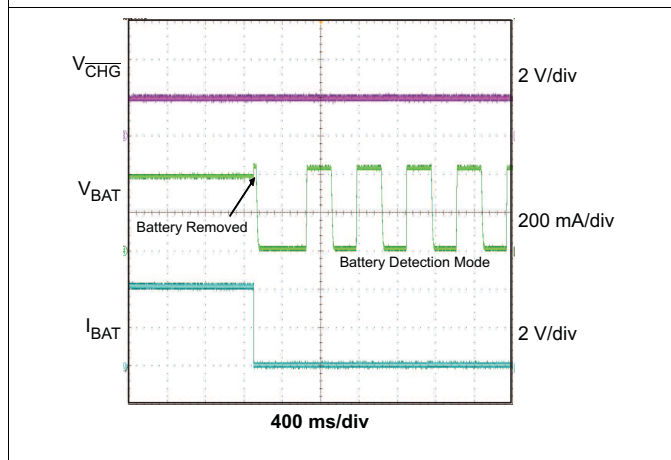

Figure 25. Battery Detection -- Removal

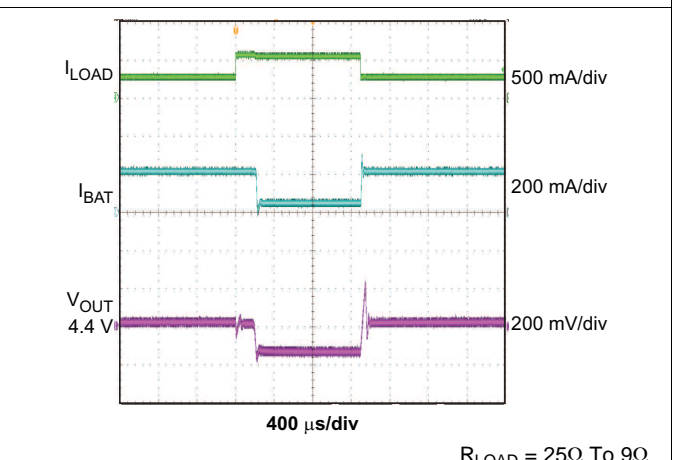

Figure 26. Entering And Exiting DPPM Mode

R_LOAD = 25Ω To 9Ω

Typical Applications (continued)

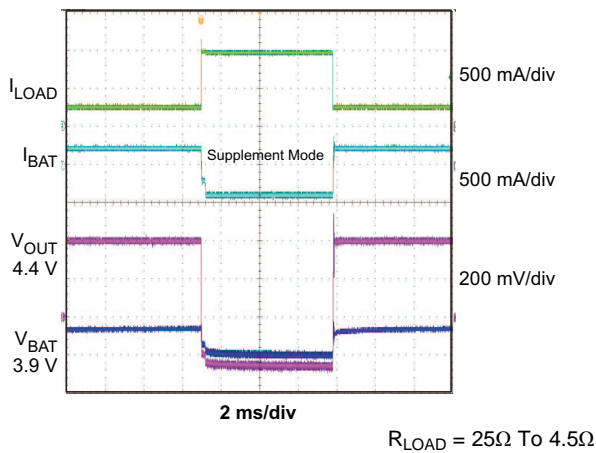

Figure 27. Entering And Exiting Battery Supplement Mode

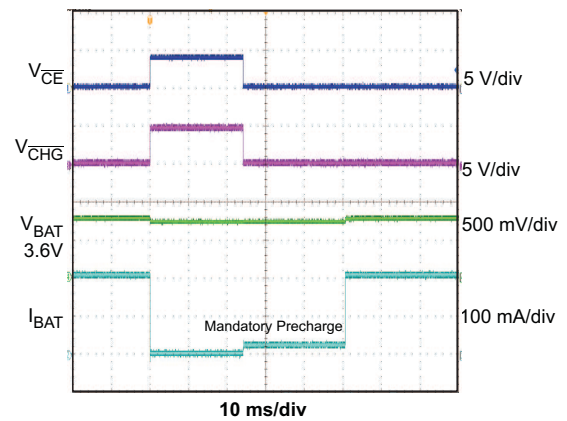

Figure 28. Charger ON/OFF Using CE

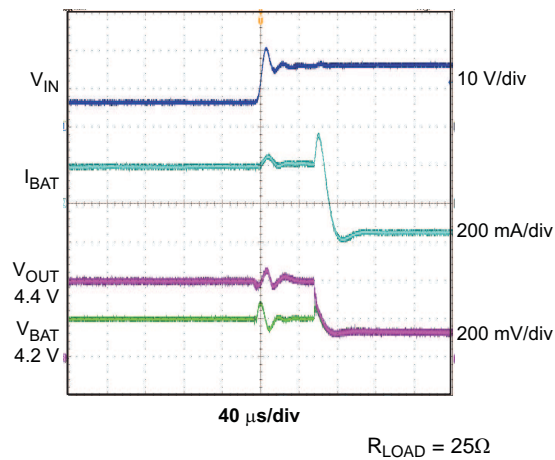

Figure 29. OVP Fault $V_{IN} = 6$ V To 15 V

Typical Applications (continued)

9.2.2 Using The bq24230 in a Host Controlled Charger Application

See [Figure 30](#) for the Design Example Schematic.

$V_{IN} = V_{UVLO}$ to V_{OVP} , $I_{FASTCHG} = 200$ mA, $I_{IN(MAX)} = 500$ mA, Battery Temperature Charge Range 0°C to 50°C , 7.5-hour Fast Charge Safety Timer.

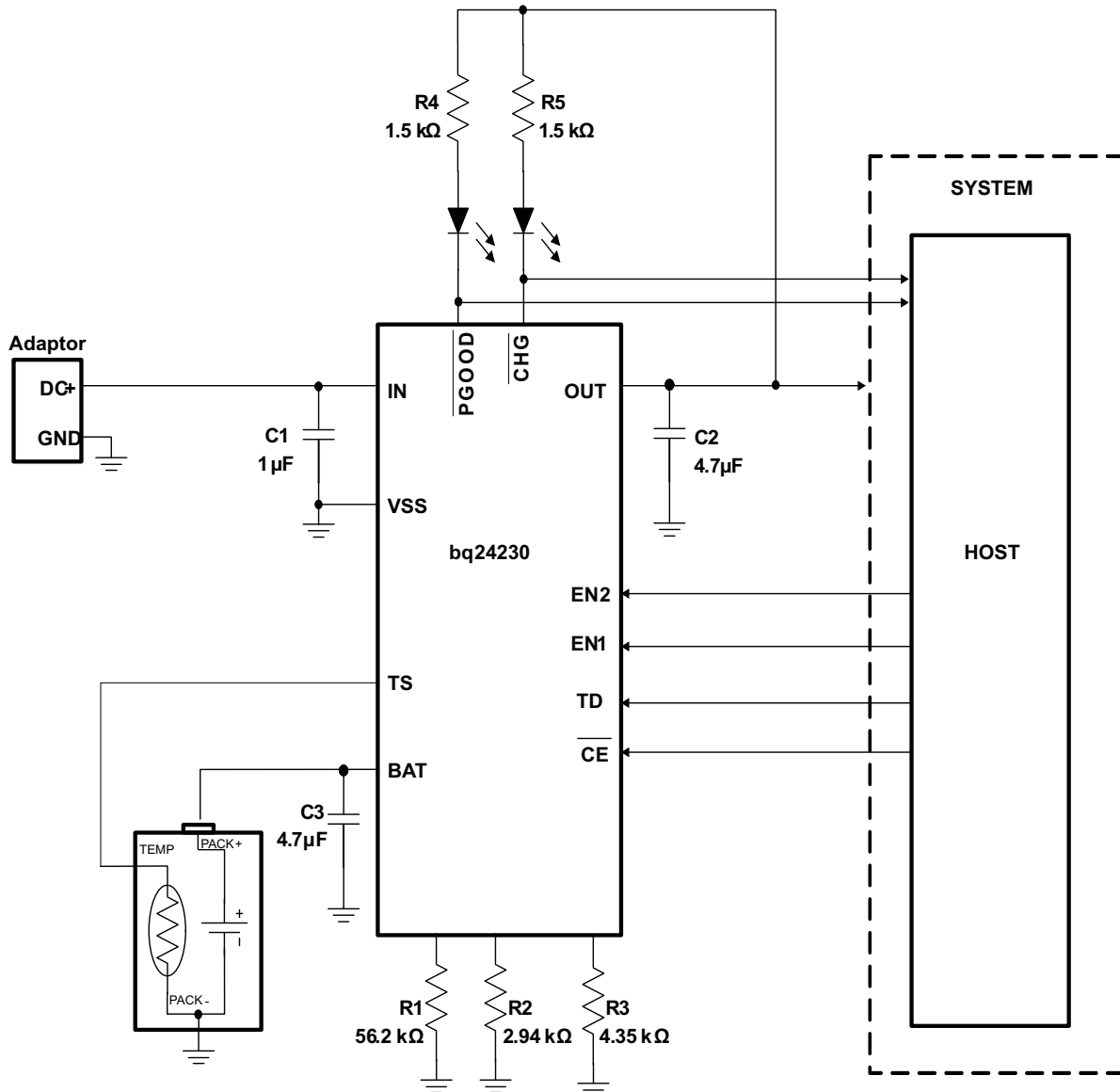

Figure 30. Using The bq24230 in a Host Controlled Charger Application

9.2.2.1 Design Requirements

See the bq24232 [Design Requirements](#).

9.2.2.2 Detailed Design Procedure

See the bq24232 [Detailed Design Procedure](#).

9.2.2.3 Application Curves

See the bq24232 [Application Curves](#).

10 Power Supply Recommendations

10.1 Requirements for OUT Output

In order to provide an output voltage on SYS, the bq2423x require either a power supply between 4.35 V and 6.0 V input for bq24230 and between 4.35V and 10V for bq24232 to fully charge a battery. The supply must have at least 100 mA current rating connected to IN; or, a single-cell Li-Ion battery with voltage around 2.2 V connected to BAT. The source current rating needs to be at least 1.5 A in order to provide maximum output current to SYS.

10.2 USB Sources and Standard AC Adapters

In order for charging to occur the source voltage measured at the IN terminals of the IC, factoring in cable/trace losses from the source, must be greater than the VINDPM threshold (in USB mode), but less than the maximum values shown above. The current rating of the source must be higher than the load requirements for OUT in the application. For charging at a desired charge current of ICHRG, $IIN > (ISYS + ICHRG)$. The charger limits IIN to the current limit setting of EN1/EN2.

10.3 Half-Wave Adapters

Some low-cost adapters implement a half rectifier topology, which causes the adapter output voltage to fall below the battery voltage during part of the cycle. To enable operation with low-cost adapters under those conditions, the bq2423x family keeps the charger on for at least 20 ms (typical) after the input power puts the part in sleep mode. This feature enables use of external low-cost adapters using 50-Hz networks.

11 Layout

11.1 Layout Guidelines

- To obtain optimal performance, the decoupling capacitor from IN to GND (thermal pad) and the output filter capacitors from OUT to GND (thermal pad) must be placed as close as possible to the bq2423x, with short trace runs to both IN, OUT, and GND (thermal pad).
- All low-current GND connections must be kept separate from the high-current charge or discharge paths from the battery. Use a single-point ground technique incorporating both the small signal ground path and the power ground path.
- The high current charge paths into the IN pin and from the OUT pin must be sized appropriately for the maximum charge current in order to avoid voltage drops in these traces.
- The bq2423x family is packaged in a thermally enhanced MLP package. The package includes a thermal pad to provide an effective thermal contact between the IC and the printed-circuit board (PCB); this thermal pad is also the main ground connection for the device. Connect the thermal pad to the PCB ground connection. Full PCB design guidelines for this package are provided in the application report entitled: QFN/SON PCB Attachment ([SLUA271](#)).

11.2 Layout Example

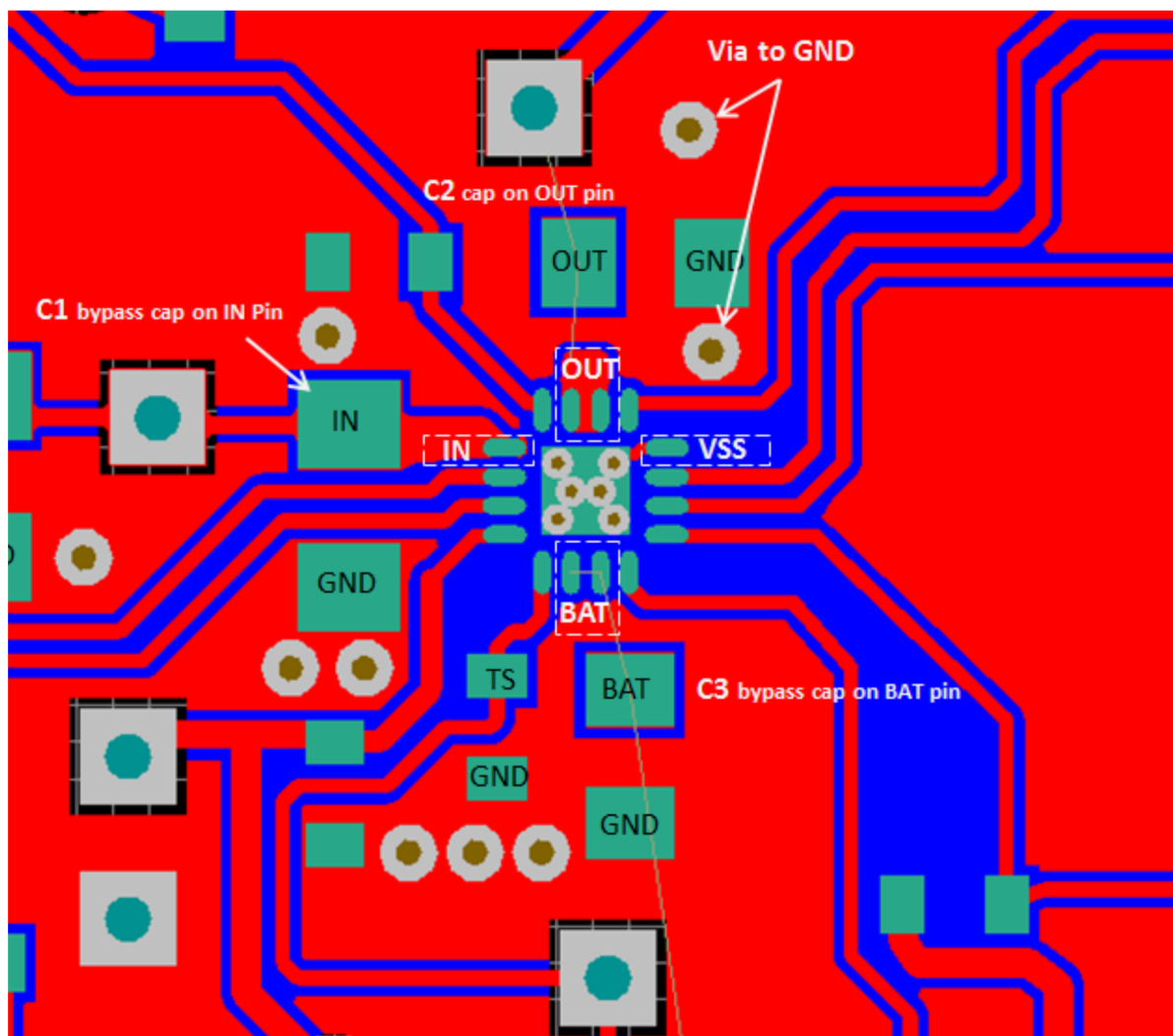

11.3 Thermal Package

The bq2423x is packaged in a thermally enhanced MLP package. The package includes a thermal pad to provide an effective thermal contact between the IC and the printed-circuit board (PCB). The power pad must be directly connected to the Vss pin. Full PCB design guidelines for this package are provided in the application report entitled: QFN/SON PCB Attachment ([SLUA271](#)). The most common measure of package thermal performance is thermal impedance (θ_{JA}) measured (or modeled) from the chip junction to the air surrounding the package surface (ambient). The mathematical expression for θ_{JA} is:

$$\theta_{JA} = (T_J - T) / P \quad (10)$$

Where:

T_J = chip junction temperature

T = ambient temperature

P = device power dissipation

Factors that can greatly influence the measurement and calculation of θ_{JA} include:

1. Whether the device is board mounted
2. Trace size, composition, thickness, and geometry
3. Orientation of the device (horizontal or vertical)
4. Volume of the ambient air surrounding the device under test and airflow

Thermal Package (continued)

- Whether other surfaces are in close proximity to the device being tested

Due to the charge profile of Li-ion batteries, the maximum power dissipation is typically seen at the beginning of the charge cycle when the battery voltage is at its lowest. Typically, after fast charge begins, the pack voltage increases to ~3.4 V within the first 2 minutes. The thermal time constant of the assembly typically takes a few minutes to heat up so when doing maximum power dissipation calculations, 3.4 V is a good minimum voltage to use. This is easy to verify, with the system and a fully discharged battery, by plotting temperature on the bottom of the PCB under the IC (pad must have multiple vias), the charge current and the battery voltage as a function of time. The fast-charge current starts to taper off if the part goes into thermal regulation.

The device power dissipation, P , is a function of the charge rate and the voltage drop across the internal PowerFET. It can be calculated from the following equation when a battery pack is being charged :

$$P = [V_{(IN)} - V_{(OUT)}] \times I_{(OUT)} + [V_{(OUT)} - V_{(BAT)}] \times I_{(BAT)} \quad (11)$$

The thermal loop feature reduces the charge current to limit excessive IC junction temperature. It is recommended that the design not run in thermal regulation for typical operating conditions (nominal input voltage and nominal ambient temperatures) and use the feature for nontypical situations such as hot environments or higher than normal input source voltage. With that said, the IC still performs as described, if the thermal loop is always active.

12 Device and Documentation Support

12.1 Documentation Support

12.1.1 Related Documentation

Application report *QFN/SON PCB Attachment*, [SLUA271](#)

12.2 Related Links

The table below lists quick access links. Categories include technical documents, support and community resources, tools and software, and quick access to sample or buy.

Table 5. Related Links

PARTS	PRODUCT FOLDER	SAMPLE & BUY	TECHNICAL DOCUMENTS	TOOLS & SOFTWARE	SUPPORT & COMMUNITY
bq24230	Click here	Click here	Click here	Click here	Click here
bq24232	Click here	Click here	Click here	Click here	Click here

12.3 Trademarks

Bluetooth is a trademark of Bluetooth SIG, Inc..
 All other trademarks are the property of their respective owners.

12.4 Electrostatic Discharge Caution



These devices have limited built-in ESD protection. The leads should be shorted together or the device placed in conductive foam during storage or handling to prevent electrostatic damage to the MOS gates.

12.5 Glossary

[SLYZ022](#) — *TI Glossary*.

This glossary lists and explains terms, acronyms, and definitions.

13 Mechanical, Packaging, and Orderable Information

The following pages include mechanical, packaging, and orderable information. This information is the most current data available for the designated devices. This data is subject to change without notice and revision of this document. For browser-based versions of this data sheet, refer to the left-hand navigation.

PACKAGING INFORMATION

Orderable Device	Status (1)	Package Type	Package Drawing	Pins	Package Qty	Eco Plan (2)	Lead finish/ Ball material (6)	MSL Peak Temp (3)	Op Temp (°C)	Device Marking (4/5)	Samples
BQ24230RGTR	ACTIVE	VQFN	RGT	16	3000	RoHS & Green	NIPDAU	Level-2-260C-1 YEAR	-40 to 85	CGN	Samples
BQ24230RGTT	ACTIVE	VQFN	RGT	16	250	RoHS & Green	NIPDAU	Level-2-260C-1 YEAR	-40 to 85	CGN	Samples
BQ24232RGTR	ACTIVE	VQFN	RGT	16	3000	RoHS & Green	NIPDAU	Level-2-260C-1 YEAR	-40 to 85	NXK	Samples
BQ24232RGTT	ACTIVE	VQFN	RGT	16	250	RoHS & Green	NIPDAU	Level-2-260C-1 YEAR	-40 to 85	NXK	Samples

(1) The marketing status values are defined as follows:

ACTIVE: Product device recommended for new designs.

LIFEBUY: TI has announced that the device will be discontinued, and a lifetime-buy period is in effect.

NRND: Not recommended for new designs. Device is in production to support existing customers, but TI does not recommend using this part in a new design.

PREVIEW: Device has been announced but is not in production. Samples may or may not be available.

OBSELETE: TI has discontinued the production of the device.

(2) **RoHS:** TI defines "RoHS" to mean semiconductor products that are compliant with the current EU RoHS requirements for all 10 RoHS substances, including the requirement that RoHS substance do not exceed 0.1% by weight in homogeneous materials. Where designed to be soldered at high temperatures, "RoHS" products are suitable for use in specified lead-free processes. TI may reference these types of products as "Pb-Free".

RoHS Exempt: TI defines "RoHS Exempt" to mean products that contain lead but are compliant with EU RoHS pursuant to a specific EU RoHS exemption.

Green: TI defines "Green" to mean the content of Chlorine (Cl) and Bromine (Br) based flame retardants meet JS709B low halogen requirements of <=1000ppm threshold. Antimony trioxide based flame retardants must also meet the <=1000ppm threshold requirement.

(3) MSL, Peak Temp. - The Moisture Sensitivity Level rating according to the JEDEC industry standard classifications, and peak solder temperature.

(4) There may be additional marking, which relates to the logo, the lot trace code information, or the environmental category on the device.

(5) Multiple Device Markings will be inside parentheses. Only one Device Marking contained in parentheses and separated by a "-" will appear on a device. If a line is indented then it is a continuation of the previous line and the two combined represent the entire Device Marking for that device.

(6) Lead finish/Ball material - Orderable Devices may have multiple material finish options. Finish options are separated by a vertical ruled line. Lead finish/Ball material values may wrap to two lines if the finish value exceeds the maximum column width.

Important Information and Disclaimer:The information provided on this page represents TI's knowledge and belief as of the date that it is provided. TI bases its knowledge and belief on information provided by third parties, and makes no representation or warranty as to the accuracy of such information. Efforts are underway to better integrate information from third parties. TI has taken and

continues to take reasonable steps to provide representative and accurate information but may not have conducted destructive testing or chemical analysis on incoming materials and chemicals. TI and TI suppliers consider certain information to be proprietary, and thus CAS numbers and other limited information may not be available for release.

In no event shall TI's liability arising out of such information exceed the total purchase price of the TI part(s) at issue in this document sold by TI to Customer on an annual basis.

TAPE AND REEL INFORMATION

QUADRANT ASSIGNMENTS FOR PIN 1 ORIENTATION IN TAPE

*All dimensions are nominal

Device	Package Type	Package Drawing	Pins	SPQ	Reel Diameter (mm)	Reel Width W1 (mm)	A0 (mm)	B0 (mm)	K0 (mm)	P1 (mm)	W (mm)	Pin1 Quadrant
BQ24230RGTR	VQFN	RGT	16	3000	330.0	12.4	3.3	3.3	1.1	8.0	12.0	Q2
BQ24230RGTT	VQFN	RGT	16	250	180.0	12.4	3.3	3.3	1.1	8.0	12.0	Q2
BQ24230RGTT	VQFN	RGT	16	250	180.0	12.4	3.3	3.3	1.1	8.0	12.0	Q2
BQ24232RGTR	VQFN	RGT	16	3000	330.0	12.4	3.3	3.3	1.1	8.0	12.0	Q2
BQ24232RGTT	VQFN	RGT	16	250	180.0	12.4	3.3	3.3	1.1	8.0	12.0	Q2

TAPE AND REEL BOX DIMENSIONS

*All dimensions are nominal

Device	Package Type	Package Drawing	Pins	SPQ	Length (mm)	Width (mm)	Height (mm)
BQ24230RGTR	VQFN	RGT	16	3000	346.0	346.0	33.0
BQ24230RGTT	VQFN	RGT	16	250	210.0	185.0	35.0
BQ24230RGTT	VQFN	RGT	16	250	210.0	185.0	35.0
BQ24232RGTR	VQFN	RGT	16	3000	367.0	367.0	35.0
BQ24232RGTT	VQFN	RGT	16	250	210.0	185.0	35.0

RGT 16

GENERIC PACKAGE VIEW

VQFN - 1 mm max height

PLASTIC QUAD FLATPACK - NO LEAD

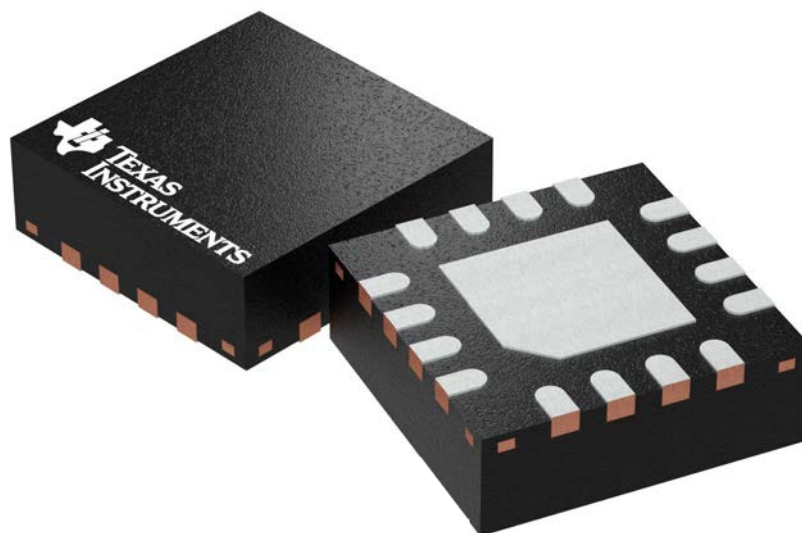

Images above are just a representation of the package family, actual package may vary.
Refer to the product data sheet for package details.

4203495/1

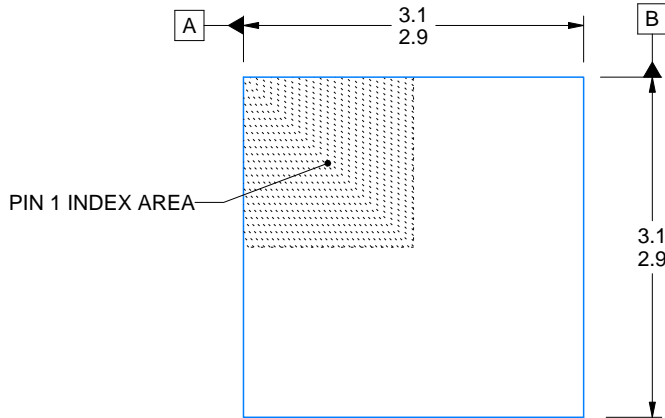
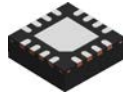

SIDE WALL METAL THICKNESS DIM A	
OPTION 1	OPTION 2
0.1	0.2

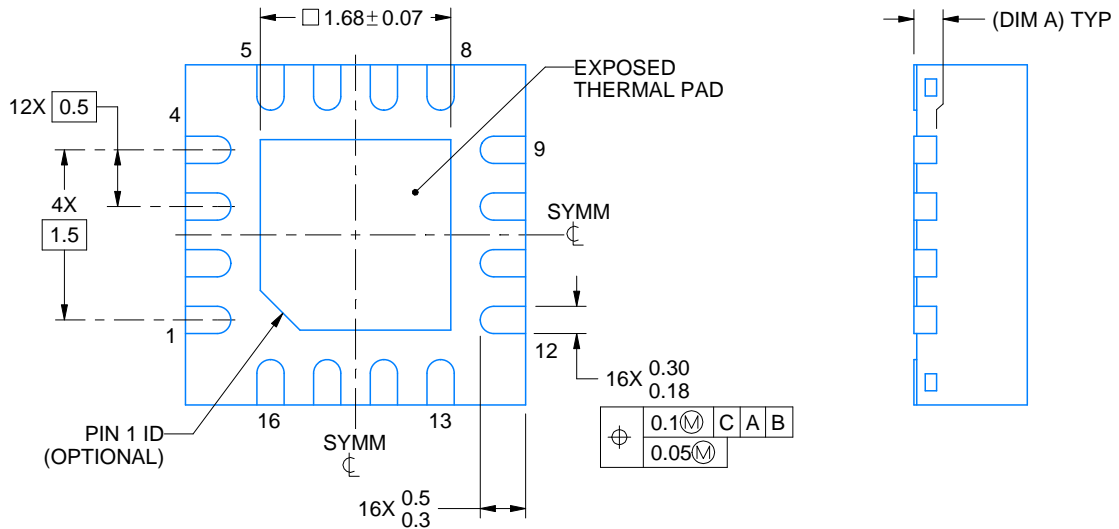
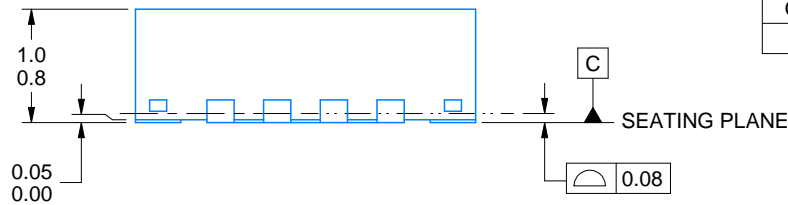

4222419/D 04/2022

NOTES:

1. All linear dimensions are in millimeters. Any dimensions in parenthesis are for reference only. Dimensioning and tolerancing per ASME Y14.5M.
2. This drawing is subject to change without notice.
3. The package thermal pad must be soldered to the printed circuit board for thermal and mechanical performance.

EXAMPLE BOARD LAYOUT

RGT0016C

VQFN - 1 mm max height

PLASTIC QUAD FLATPACK - NO LEAD

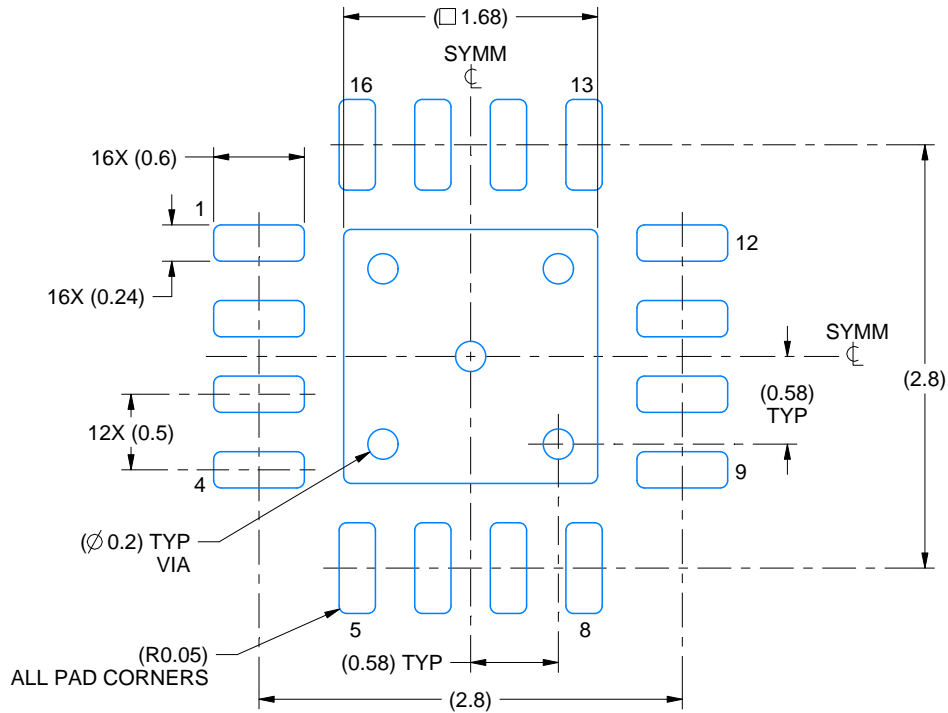

LAND PATTERN EXAMPLE
EXPOSED METAL SHOWN
SCALE:20X

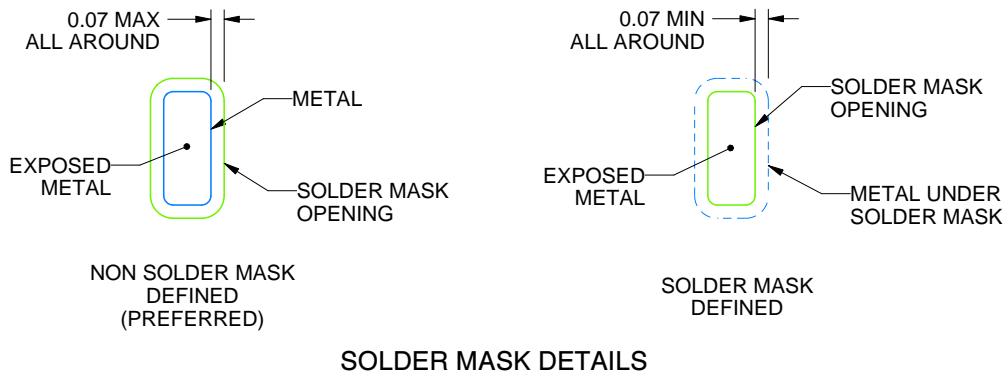

4222419/D 04/2022

NOTES: (continued)

4. This package is designed to be soldered to a thermal pad on the board. For more information, see Texas Instruments literature number SLUA271 (www.ti.com/lit/sluea271).
5. Vias are optional depending on application, refer to device data sheet. If any vias are implemented, refer to their locations shown on this view. It is recommended that vias under paste be filled, plugged or tented.

EXAMPLE STENCIL DESIGN

RGT0016C

VQFN - 1 mm max height

PLASTIC QUAD FLATPACK - NO LEAD

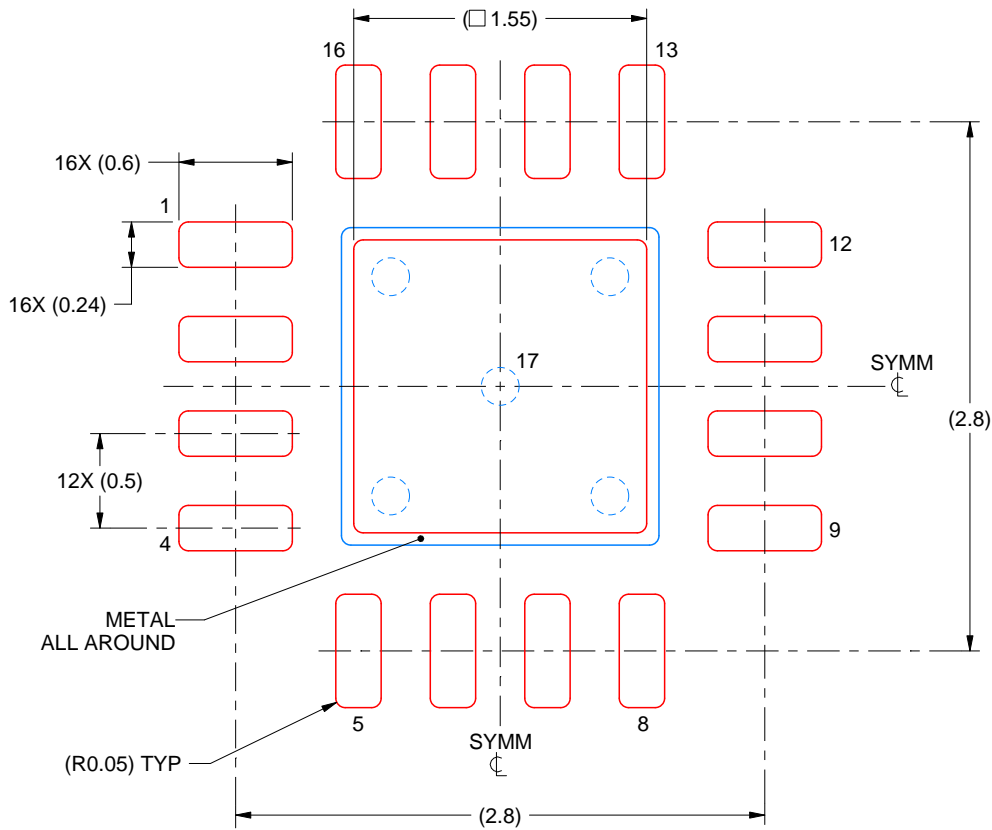

SOLDER PASTE EXAMPLE
BASED ON 0.125 mm THICK STENCIL

EXPOSED PAD 17:
85% PRINTED SOLDER COVERAGE BY AREA UNDER PACKAGE
SCALE:25X

4222419/D 04/2022

NOTES: (continued)

6. Laser cutting apertures with trapezoidal walls and rounded corners may offer better paste release. IPC-7525 may have alternate design recommendations.

IMPORTANT NOTICE AND DISCLAIMER

TI PROVIDES TECHNICAL AND RELIABILITY DATA (INCLUDING DATA SHEETS), DESIGN RESOURCES (INCLUDING REFERENCE DESIGNS), APPLICATION OR OTHER DESIGN ADVICE, WEB TOOLS, SAFETY INFORMATION, AND OTHER RESOURCES "AS IS" AND WITH ALL FAULTS, AND DISCLAIMS ALL WARRANTIES, EXPRESS AND IMPLIED, INCLUDING WITHOUT LIMITATION ANY IMPLIED WARRANTIES OF MERCHANTABILITY, FITNESS FOR A PARTICULAR PURPOSE OR NON-INFRINGEMENT OF THIRD PARTY INTELLECTUAL PROPERTY RIGHTS.

These resources are intended for skilled developers designing with TI products. You are solely responsible for (1) selecting the appropriate TI products for your application, (2) designing, validating and testing your application, and (3) ensuring your application meets applicable standards, and any other safety, security, regulatory or other requirements.

These resources are subject to change without notice. TI grants you permission to use these resources only for development of an application that uses the TI products described in the resource. Other reproduction and display of these resources is prohibited. No license is granted to any other TI intellectual property right or to any third party intellectual property right. TI disclaims responsibility for, and you will fully indemnify TI and its representatives against, any claims, damages, costs, losses, and liabilities arising out of your use of these resources.

TI's products are provided subject to [TI's Terms of Sale](#) or other applicable terms available either on [ti.com](https://www.ti.com) or provided in conjunction with such TI products. TI's provision of these resources does not expand or otherwise alter TI's applicable warranties or warranty disclaimers for TI products.

TI objects to and rejects any additional or different terms you may have proposed.

Mailing Address: Texas Instruments, Post Office Box 655303, Dallas, Texas 75265
Copyright © 2024, Texas Instruments Incorporated

Looking for pricing, stock, or lifecycle information?

Click below to explore more details on WIN SOURCE:

 [View BQ24232RGTR](#) on WIN SOURCE

 [Texas Instruments](#) Information

Optimize Your Supply Chain with WIN SOURCE Solutions

-  Global Sourcing Solution
-  Obsolete Management
-  Cost Control Management
-  Shortage Management
-  Alternative Solution
-  Excess Inventory Management