



**THE DATASHEET OF
TISP61089QBDR-S**





**PROGRAMMABLE OVERVOLTAGE PROTECTOR
QUAD FORWARD-CONDUCTING P-GATE THYRISTOR**

CUSTOMER: Technicolor

TISP61089QB SLIC Overvoltage Protector

- Quad Voltage-Programmable Protector**
- Wide -20 V to -155 V Programming Range
 - Low 5 mA max. Gate Triggering Current
 - High 150 mA min. Holding Current
 - Rated for ITU-T impulses

UL Recognized Component

Description

Bourns® TISP61089QB is a quad forward-conducting buffered p-gate overvoltage protector. It is designed to protect monolithic SLICs (Subscriber Line Interface Circuits) against overvoltages on the telephone line caused by lightning, a.c. power contact and induction. The TISP61089QB limits voltages that exceed the SLIC supply rail voltage. The TISP61089QB parameters are specified to allow equipment compliance with ITU-T K.20 and K.21.

The SLIC line driver section is typically powered from 0 V (ground) and a negative voltage in the region of -20 V to -155 V. The protector gate is connected to this negative supply. This references the protection (clipping) voltage to the negative supply voltage. As the protection voltage will then track the negative supply voltage the overvoltage stress on the SLIC is minimized.

Positive overvoltages are clipped to ground by diode forward conduction. Negative overvoltages are initially clipped close to the SLIC negative supply rail value. If sufficient current is available from the overvoltage, then the protector will crowbar into a low voltage on-state condition. As the overvoltage subsides, the high holding current of the crowbar helps prevent d.c. latchup.

These monolithic protection devices are fabricated in ion-implanted planar vertical power structures for high reliability and are virtually transparent in normal operation. The TISP61089QB buffered gate design reduces the loading on the SLIC supply during overvoltages caused by power cross and induction. The TISP61089QB is available in an 8-pin plastic small-outline surface mount package.

Agency Recognition

Description	
UL	File Number: E215609

D Package (Top View)

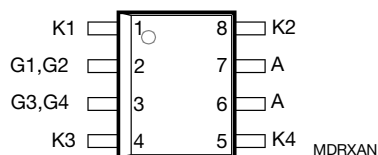

Device Symbol

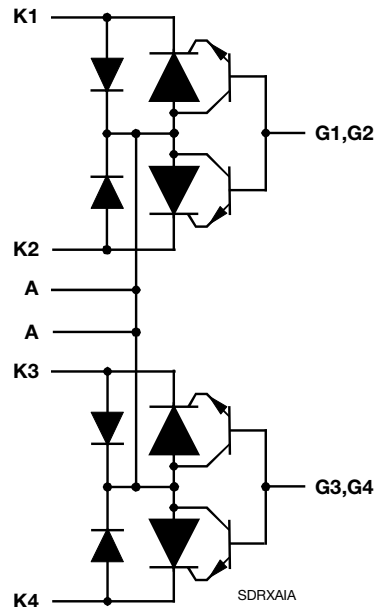

How to Order

Device	Package	Carrier	Order As	Marking Code	Standard Quantity
TISP61089QB	8 Pin Small Outline (D008)	Embossed Tape Reeled	TISP61089QBDR-T	1089QB	2500

JULY 2010 – REVISED JULY 2019

*RoHS Directive 2015/863, Mar 31, 2015 and Annex. Specifications are subject to change without notice. Users should verify actual device performance in their specific applications. The products described herein and this document are subject to specific legal disclaimers as set forth on the last page of this document, and at www.bourns.com/docs/legal/disclaimer.pdf.



WARNING Cancer and Reproductive Harm
www.P65Warnings.ca.gov

TISP61089QB SLIC Overvoltage Protector

BOURNS®

Absolute Maximum Ratings, $T_J = 25\text{ }^\circ\text{C}$ (Unless Otherwise Noted)

Rating	Symbol	Value	Unit
Repetitive peak off-state voltage, $I_G = 0$	V_{DRM}	-170	V
Repetitive peak gate-cathode voltage, $V_{KA} = 0$	V_{GKRM}	-167	V
Non-repetitive peak on-state pulse current, $V_{GG} = -48\text{ V}$ (see Note 2) 8/20 μs (ITU-T K.44, May 2012, Appendix A.3-5, see Note 4)	I_{TSP}	90	A
Non-repetitive peak on-state current, 60 Hz (see Notes 1, 2 and 3) 900 s	I_{TSM}	0.5	A
Non-repetitive peak gate current, 2/10 μs pulse, cathodes commoned (see Notes 1 and 2)	I_{GSM}	40	A
Junction temperature	T_J	-40 to +150	$^\circ\text{C}$
Storage temperature range	T_{stg}	-40 to +150	$^\circ\text{C}$

- NOTES: 1. Initially the protector must be in thermal equilibrium with $T_J = 25\text{ }^\circ\text{C}$. The surge may be repeated after the device returns to its initial conditions.
2. These non-repetitive rated currents are peak values for either polarity. The rated current values may be applied to any cathode-anode terminal pair.
3. EIA/JESD51-2 environment and EIA/JESD51-7 high effective thermal conductivity test board (multi-layer) connected with 0.6 mm printed wiring track widths.
4. Combination wave generator as specified in ITU-T K.20, K.21, K.44.

Recommended Operating Conditions

	Min	Typ	Max	Unit
C_G Gate decoupling capacitor		100		nF

Electrical Characteristics, $T_J = 25\text{ }^\circ\text{C}$ (Unless Otherwise Noted)

Parameter	Test Conditions	Min	Typ	Max	Unit
I_D Off-state current	$V_D = V_{DRM}$, $V_{GK} = 0$			-5	μA
$V_{(BO)}$ Breakover voltage	10/700 μs , $I_T = -40\text{ A}$, $R_S = 55\ \Omega$, $V_{GG} = -48\text{ V}$, $C_G = 100\text{ nF}$			-64	V
V_F Forward voltage	$I_F = 5\text{ A}$, $t_w = 200\ \mu\text{s}$			3	V
V_{FRM} Peak forward recovery voltage	10/700 μs , $I_F = 40\text{ A}$, $R_S = 55\ \Omega$, $V_{GG} = -48\text{ V}$, $C_G = 100\text{ nF}$		12		V
I_H Holding current	$I_T = -1\text{ A}$, $di/dt = 1\text{ A/ms}$, $V_{GG} = -100\text{ V}$	-150			mA
I_{GAS} Gate reverse current	$V_{GG} = V_{GK} = V_{GKRM}$, $V_{KA} = 0$			-5	μA
I_{GT} Gate trigger current	$I_T = 3\text{ A}$, $t_{p(g)} \geq 20\ \mu\text{s}$, $V_{GG} = -100\text{ V}$			5	mA
V_{GT} Gate trigger voltage	$I_T = 3\text{ A}$, $t_{p(g)} \geq 20\ \mu\text{s}$, $V_{GG} = -100\text{ V}$			2.5	V
C_{AK} Anode-cathode off-state capacitance	$f = 1\text{ MHz}$, $V_d = 1\text{ V}$, $I_G = 0$, (see Note 5)	$V_D = -3\text{ V}$		100	pF
		$V_D = -48\text{ V}$		50	

- NOTE: 5. These capacitance measurements employ a three terminal capacitance bridge incorporating a guard circuit. The unmeasured device terminals are a.c. connected to the guard terminal of the bridge.

JULY 2010 – REVISED JULY 2019

Specifications are subject to change without notice.

Users should verify actual device performance in their specific applications.

The products described herein and this document are subject to specific legal disclaimers as set forth on the last page of this document, and at www.bourns.com/docs/legal/disclaimer.pdf.

Thermal Characteristics

Parameter	Test Conditions	Min	Typ	Max	Unit
$R_{\theta JA}$	Junction to free air thermal resistance			160	$^{\circ}C/W$

*Test Conditions: $P_{tot} = 0.8 W, T_A = 25^{\circ}C$
5 cm², FR4 PCB*

Parameter Measurement Information

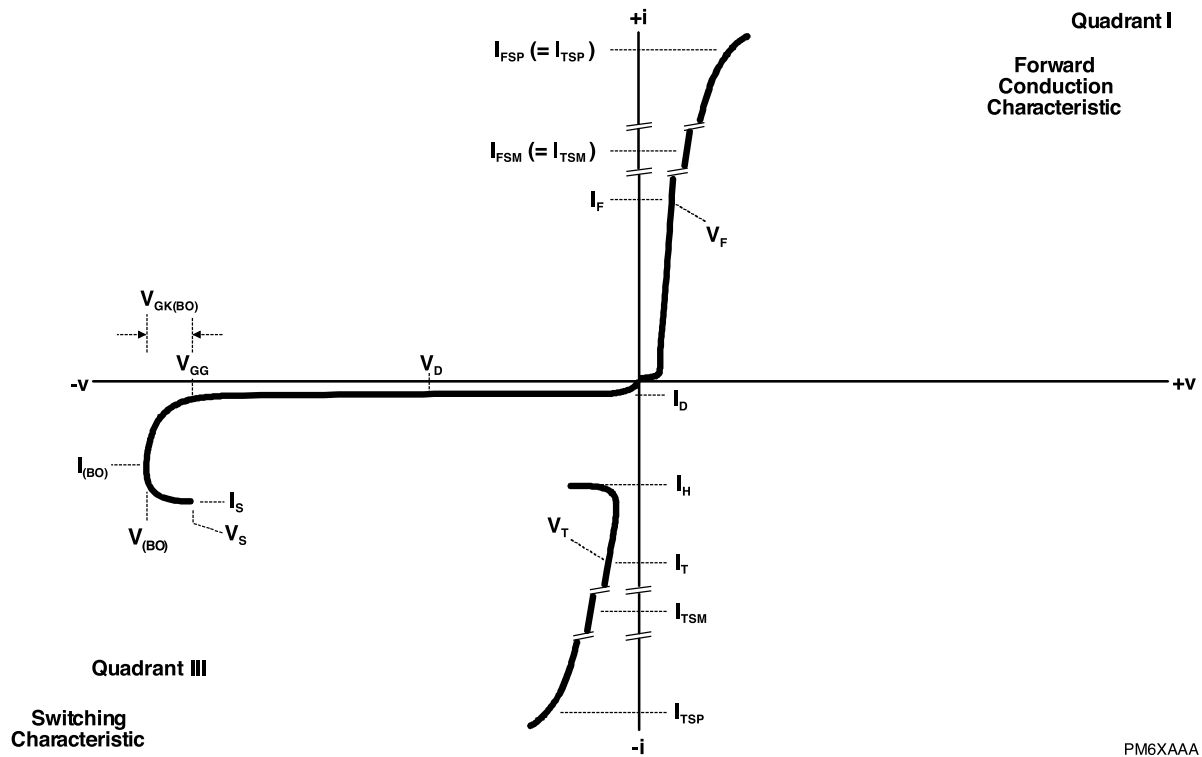

PM6XAAA

Figure 1. Voltage-Current Characteristic
Unless Otherwise Noted, All Voltages are Referenced to the Anode

TISP61089QB SLIC Overvoltage Protector

BOURNS®

Applications Information

Typical Applications Circuit

Figure 2 shows a typical TISP61089QB SLIC card protection circuit. The incoming line conductors, RING1/RING2 and TIP1/TIP2, connect to the relay matrix via the series overcurrent protection. Positive temperature coefficient (PTC) thermistors can be used for overcurrent protection. The resistance of the PTC thermistor will reduce the prospective current from the surge generator for the TISP61089QB.

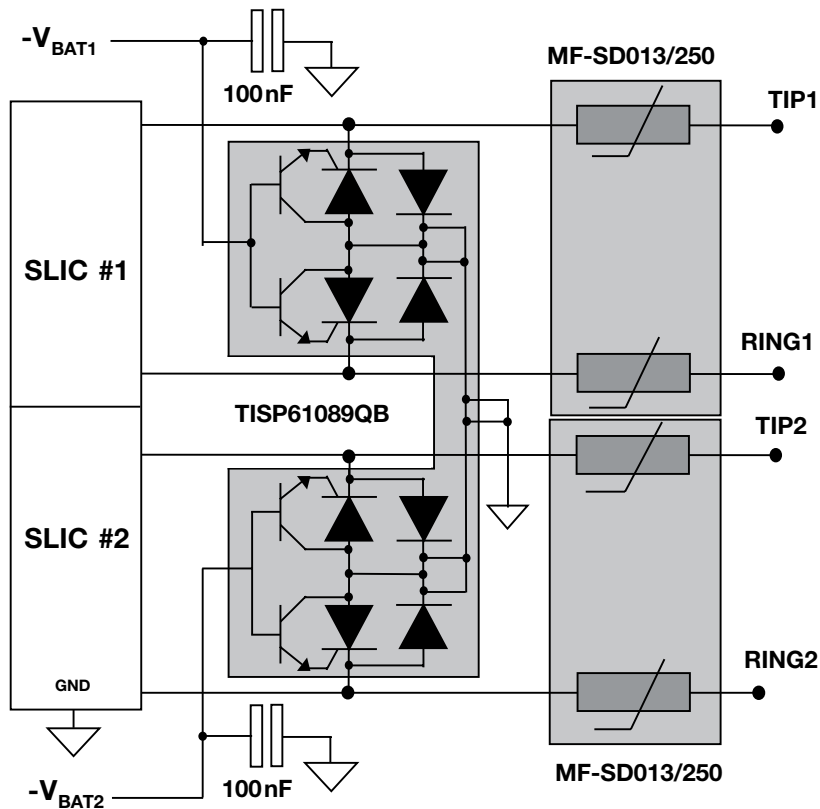

BOURNS®

Asia-Pacific: Tel: +886-2 2562-4117 • Email: asiacus@bourns.com

Europe: Tel: +36 88 885 877 • Email: eurocus@bourns.com

The Americas: Tel: +1-951 781-5500 • Email: americus@bourns.com

www.bourns.com

JULY 2010 – REVISED JULY 2019

"TISP" is a trademark of Bourns, Ltd., a Bourns Company, and is registered in the U.S. Patent and Trademark Office.

"Bourns" is a registered trademark of Bourns, Inc. in the U.S. and other countries.

Specifications are subject to change without notice.

Users should verify actual device performance in their specific applications.

The products described herein and this document are subject to specific legal disclaimers as set forth on the last page of this document, and at www.bourns.com/docs/legal/disclaimer.pdf.

This legal disclaimer applies to purchasers and users of Bourns® products manufactured by or on behalf of Bourns, Inc. and its affiliates (collectively, “Bourns”).

Unless otherwise expressly indicated in writing, Bourns® products and data sheets relating thereto are subject to change without notice. Users should check for and obtain the latest relevant information and verify that such information is current and complete before placing orders for Bourns® products.

The characteristics and parameters of a Bourns® product set forth in its data sheet are based on laboratory conditions, and statements regarding the suitability of products for certain types of applications are based on Bourns’ knowledge of typical requirements in generic applications. The characteristics and parameters of a Bourns® product in a user application may vary from the data sheet characteristics and parameters due to (i) the combination of the Bourns® product with other components in the user’s application, or (ii) the environment of the user application itself. The characteristics and parameters of a Bourns® product also can and do vary in different applications and actual performance may vary over time. Users should always verify the actual performance of the Bourns® product in their specific devices and applications, and make their own independent judgments regarding the amount of additional test margin to design into their device or application to compensate for differences between laboratory and real world conditions.

Unless Bourns has explicitly designated an individual Bourns® product as meeting the requirements of a particular industry standard (e.g., ISO/TS 16949) or a particular qualification (e.g., UL listed or recognized), Bourns is not responsible for any failure of an individual Bourns® product to meet the requirements of such industry standard or particular qualification. Users of Bourns® products are responsible for ensuring compliance with safety-related requirements and standards applicable to their devices or applications.

Bourns® products are not recommended, authorized or intended for use in nuclear, lifesaving, life-critical or life-sustaining applications, nor in any other applications where failure or malfunction may result in personal injury, death, or severe property or environmental damage. Unless expressly and specifically approved in writing by two authorized Bourns representatives on a case-by-case basis, use of any Bourns® products in such unauthorized applications might not be safe and thus is at the user’s sole risk. Life-critical applications include devices identified by the U.S. Food and Drug Administration as Class III devices and generally equivalent classifications outside of the United States.

Bourns expressly identifies those Bourns® standard products that are suitable for use in automotive applications on such products’ data sheets in the section entitled “Applications.” Unless expressly and specifically approved in writing by two authorized Bourns representatives on a case-by-case basis, use of any other Bourns® standard products in an automotive application might not be safe and thus is not recommended, authorized or intended and is at the user’s sole risk. If Bourns expressly identifies a sub-category of automotive application in the data sheet for its standard products (such as infotainment or lighting), such identification means that Bourns has reviewed its standard product and has determined that if such Bourns® standard product is considered for potential use in automotive applications, it should only be used in such sub-category of automotive applications. Any reference to Bourns® standard product in the data sheet as compliant with the AEC-Q standard or “automotive grade” does not by itself mean that Bourns has approved such product for use in an automotive application.

Bourns® standard products are not tested to comply with United States Federal Aviation Administration standards generally or any other generally equivalent governmental organization standard applicable to products designed or manufactured for use in aircraft or space applications. Bourns expressly identifies Bourns® standard products that are suitable for use in aircraft or space applications on such products’ data sheets in the section entitled “Applications.” Unless expressly and specifically approved in writing by two authorized Bourns representatives on a case-by-case basis, use of any other Bourns® standard product in an aircraft or space application might not be safe and thus is not recommended, authorized or intended and is at the user’s sole risk.

The use and level of testing applicable to Bourns® custom products shall be negotiated on a case-by-case basis by Bourns and the user for which such Bourns® custom products are specially designed. Absent a written agreement between Bourns and the user regarding the use and level of such testing, the above provisions applicable to Bourns® standard products shall also apply to such Bourns® custom products.

Users shall not sell, transfer, export or re-export any Bourns® products or technology for use in activities which involve the design, development, production, use or stockpiling of nuclear, chemical or biological weapons or missiles, nor shall they use Bourns® products or technology in any facility which engages in activities relating to such devices. The foregoing restrictions apply to all uses and applications that violate national or international prohibitions, including embargos or international regulations. Further, Bourns® products and Bourns technology and technical data may not under any circumstance be exported or re-exported to countries subject to international sanctions or embargoes. Bourns® products may not, without prior authorization from Bourns and/or the U.S. Government, be resold, transferred, or re-exported to any party not eligible to receive U.S. commodities, software, and technical data.

To the maximum extent permitted by applicable law, Bourns disclaims (i) any and all liability for special, punitive, consequential, incidental or indirect damages or lost revenues or lost profits, and (ii) any and all implied warranties, including implied warranties of fitness for particular purpose, non-infringement and merchantability.



For your convenience, copies of this Legal Disclaimer Notice with German, Spanish, Japanese, Traditional Chinese and Simplified Chinese bilingual versions are available at:

Web Page: <http://www.bourns.com/legal/disclaimers-terms-and-policies>

PDF: <http://www.bourns.com/docs/Legal/disclaimer.pdf>

Looking for pricing, stock, or lifecycle information?

Click below to explore more details on WIN SOURCE:

-  [View TISP61089QBDR-S on WIN SOURCE](#)
-  [Bourns Inc. Information](#)

Optimize Your Supply Chain with WIN SOURCE Solutions

-  Global Sourcing Solution
-  Obsolete Management
-  Cost Control Management
-  Shortage Management
-  Alternative Solution
-  Excess Inventory Management