



THE DATASHEET OF OPA365AIDBVR



TLVx365 50-MHz, Zero-Crossover, High-CMRR, RRIO Operational Amplifiers

1 Features

- Gain bandwidth: 50 MHz
- Zero-crossover distortion topology:
 - CMRR: 115 dB (typical)
 - Rail-to-rail input and output
 - Input 100 mV beyond supply rail
- Noise: 4.5 nV/√Hz
- Slew rate: 27 V/μs
- Fast settling: 0.2 μs to 0.01%
- Precision:
 - Offset drift: 2 μV/°C (maximum)
 - Input bias current: 20 pA (maximum)
- Operating voltage: 2.2-V to 5.5-V

2 Applications

- Signal conditioning
- [Data acquisition](#)
- Active filters
- Test equipment
- [Audio](#)
- Wideband amplifiers
- [Rack server](#)

3 Description

The TLV365 and TLV2365 devices (TLVx365) are a family of zero-crossover, rail-to-rail input and output, CMOS operational amplifiers, optimized for low voltage and cost-sensitive applications. Low-noise (4.5 nV/√Hz) and high-speed operation (50-MHz gain bandwidth) make these devices an excellent choice for driving sampling analog-to-digital converters (ADCs) in applications such as low-side current sensing, audio, signal conditioning, and sensor amplification.

Special features include an excellent common-mode rejection ratio (CMRR), no input stage crossover distortion, high input impedance, and rail-to-rail input and output swing. The input common-mode range includes both the negative and positive supplies. The output voltage swings to within 10 mV of the rails.

The TLVx365 are specified for operation from –40°C to +125°C.

Device Information

PART NUMBER	CHANNEL COUNT	PACKAGE ⁽¹⁾
TLV365	Single	DBV (SOT-23, 5)
TLV2365	Dual	D (SOIC, 8)

(1) For all available packages, see the orderable addendum at the end of the data sheet.

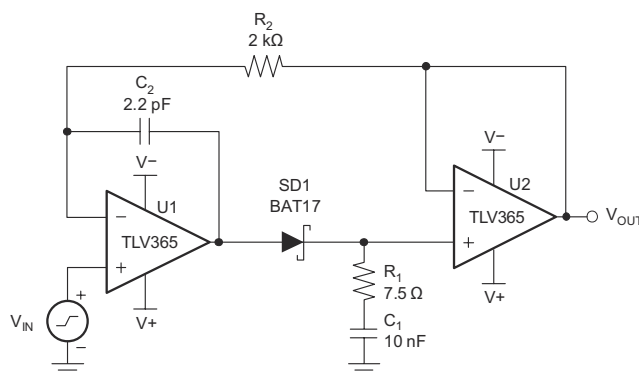

Fast-Settling Peak Detector

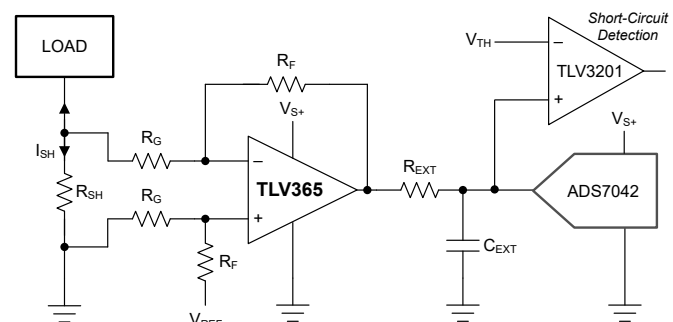

TLVx365 for Current Sensing



Table of Contents

1 Features	1	8.4 Device Functional Modes.....	13
2 Applications	1	9 Application and Implementation	14
3 Description	1	9.1 Application Information.....	14
4 Revision History	2	9.2 Typical Applications.....	16
5 Device Comparison Table	3	9.3 Power Supply Recommendations.....	17
6 Pin Configuration and Functions	3	9.4 Layout.....	18
7 Specifications	4	10 Device and Documentation Support	19
7.1 Absolute Maximum Ratings	4	10.1 Device Support.....	19
7.2 ESD Ratings.....	4	10.2 Documentation Support.....	20
7.3 Recommended Operating Conditions.....	4	10.3 Receiving Notification of Documentation Updates..	20
7.4 Thermal Information.....	4	10.4 Support Resources.....	20
7.5 Electrical Characteristics.....	5	10.5 Trademarks.....	20
7.6 Typical Characteristics.....	6	10.6 Electrostatic Discharge Caution.....	20
8 Detailed Description	10	10.7 Glossary.....	20
8.1 Overview.....	10	11 Mechanical, Packaging, and Orderable	
8.2 Functional Block Diagram.....	10	Information	20
8.3 Feature Description.....	11		

4 Revision History

NOTE: Page numbers for previous revisions may differ from page numbers in the current version.

Changes from Revision A (June 2023) to Revision B (September 2023)	Page
• Changed TLV2365 status from advanced information to production data (active).....	1

Changes from Revision * (December 2022) to Revision A (June 2023)	Page
• Changed TLV2365 status from preview to advanced information.....	1
• Added <i>Device Comparison Table</i>	3

5 Device Comparison Table

DEVICE	INPUT TYPE	OFFSET DRIFT TYPICAL ($\mu\text{V}/\text{C}$)	MINIMUM GAIN STABLE (V/V)	I_Q /CHANNEL TYPICAL (mA)	GAIN BANDWIDTH (MHz)	SLEW RATE (V/ μs)	VOLTAGE NOISE (nV/ $\sqrt{\text{Hz}}$)
TLVx365	CMOS	0.4	1	4.6	50	27	4.5
OPAx607	CMOS	0.3	6	0.9	50	24	3.8
OPAx365	CMOS	1	1	4.6	50	25	4.5

6 Pin Configuration and Functions

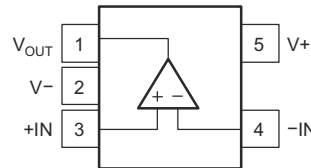

Figure 6-1. TLV365 DBV Package, 5-Pin SOT-23 (Top View)

Table 6-1. Pin Functions: TLV365

PIN		TYPE	DESCRIPTION
NAME	NO.		
-IN	4	Input	Negative (inverting) input
+IN	3	Input	Positive (noninverting) input
V-	2	—	Negative (lowest) power supply
V+	5	—	Positive (highest) power supply
V _{OUT}	1	Output	Output

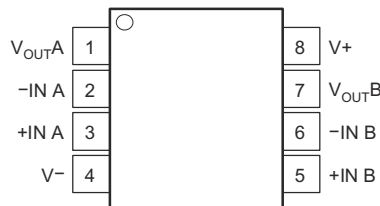

Figure 6-2. TLV2365 D Package, 8-Pin SOIC (Top View)

Pin Functions: TLV2365

PIN		TYPE	DESCRIPTION
NAME	NO.		
-IN A	2	Input	Negative (inverting) input signal, channel A
+IN A	3	Input	Positive (noninverting) input signal, channel A
-IN B	6	Input	Negative (inverting) input signal, channel B
+IN B	5	Input	Positive (noninverting) input signal, channel B
V-	4	—	Negative (lowest) power supply
V+	8	—	Positive (highest) power supply
V _{OUTA}	1	Output	Output, channel A
V _{OUTB}	7	Output	Output, channel B

7 Specifications

7.1 Absolute Maximum Ratings

Over operating free-air temperature range (unless otherwise noted)⁽¹⁾

		MIN	MAX	UNIT
V_S	Supply voltage, $V_S = (V+) - (V-)$		6	V
V_I	Input voltage	$(V-) - 0.5$	$(V+) + 0.5$	V
V_{ID}	Differential input voltage		±5	V
I_I	Continuous input current ⁽²⁾		±10	mA
I_{SC}	Output short-circuit ⁽³⁾	Continuous		
T_A	Operating temperature	-40	125	°C
T_J	Junction temperature		150	°C
T_{stg}	Storage temperature	-65	150	°C

- Operation outside the Absolute Maximum Ratings may cause permanent device damage. Absolute Maximum Ratings do not imply functional operation of the device at these or any other conditions beyond those listed under Recommended Operating Conditions. If used outside the Recommended Operating Conditions but within the Absolute Maximum Ratings, the device may not be fully functional, and this may affect device reliability, functionality, performance, and shorten the device lifetime.
- Input pins are diode-clamped to the power-supply rails. Limit the current of input signals that can swing more than 0.5 V beyond the supply rails to 10 mA or less.
- Short-circuit to ground, one amplifier per package.

7.2 ESD Ratings

			VALUE	UNIT
$V_{(ESD)}$	Electrostatic discharge	Human-body model (HBM), per ANSI/ESDA/JEDEC JS-001 ⁽¹⁾	±2000	V
		Charged device model (CDM), per ANSI/ESDA/JEDEC JS-002 ⁽²⁾	±1000	

- JEDEC document JEP155 states that 500-V HBM allows safe manufacturing with a standard ESD control process.
- JEDEC document JEP157 states that 250-V CDM allows safe manufacturing with a standard ESD control process.

7.3 Recommended Operating Conditions

over operating free-air temperature range (unless otherwise noted)

		MIN	NOM	MAX	UNIT
V_S	Supply voltage, $V_S = (V+) - (V-)$	2.2		5.5	V
T_A	Specified temperature	-40	25	125	°C

7.4 Thermal Information

THERMAL METRIC ⁽¹⁾		TLV365	TLV2365	UNIT
		DBV (SOT-23)	D (SOIC)	
		5 PINS	8 PINS	
$R_{\theta JA}$	Junction-to-ambient thermal resistance	179	140	°C/W
$R_{\theta JC(top)}$	Junction-to-case (top) thermal resistance	78	89	°C/W
$R_{\theta JB}$	Junction-to-board thermal resistance	46	80	°C/W
ψ_{JT}	Junction-to-top characterization parameter	19	28	°C/W
ψ_{JB}	Junction-to-board characterization parameter	46	80	°C/W

- For more information about traditional and new thermal metrics, see the [Semiconductor and IC Package Thermal Metrics](#) application report.

7.5 Electrical Characteristics

at $V_S = 2.2\text{ V to }5.5\text{ V}$, $T_A = 25^\circ\text{C}$, $R_L = 10\text{ k}\Omega$, $V_{CM}, V_{OUT} = \text{mid-supply}$, and gain = 1 V/V (unless otherwise noted)

PARAMETER		TEST CONDITIONS	MIN	TYP	MAX	UNIT
OFFSET VOLTAGE						
V_{OS}	Input offset voltage			± 0.4	± 1.9	mV
dV_{OS}/dT	Input offset voltage drift	$T_A = -40^\circ\text{C to }+125^\circ\text{C}$		± 0.4	± 2	$\mu\text{V}/^\circ\text{C}$
PSRR	Power-supply rejection ratio	$V_S = 2.2\text{ V to }5.5\text{ V}$, $T_A = -40\text{ to }+125^\circ\text{C}$		100		dB
INPUT BIAS CURRENT						
I_B	Input bias current			± 5	± 20	pA
		$T_A = -40^\circ\text{C to }+125^\circ\text{C}$		See Figure 7-5		
NOISE						
	Input voltage noise (peak-to-peak)	$f = 0.1\text{ Hz to }10\text{ Hz}$		5.4		μV_{PP}
e_N	Input voltage noise density	$f = 500\text{ kHz}$		4.5		$\text{nV}/\sqrt{\text{Hz}}$
i_n	Input current noise density	$f = 1\text{ kHz}$		5.8		$\text{fA}/\sqrt{\text{Hz}}$
INPUT VOLTAGE						
V_{CM}	Common-mode voltage		$(V_-) - 0.1$	$(V_+) + 0.1$		V
CMRR	Common-mode rejection ratio	$(V_-) - 100\text{ mV} < V_{CM} < (V_+) + 100\text{ mV}$ $T_A = -40^\circ\text{C to }+125^\circ\text{C}$		115		dB
				110		
INPUT IMPEDANCE						
C_{IN}	Differential			5		pF
	Common-mode			1		
OPEN-LOOP GAIN						
A_{OL}	Open-loop voltage gain	$R_L = 10\text{ k}\Omega$, $(V_-) + 0.1\text{ V} < V_{OUT} < (V_+) - 0.1\text{ V}$	100	120		dB
		$R_L = 10\text{ k}\Omega$, $T_A = -40\text{ to }+125^\circ\text{C}$	95			
		$R_L = 600\ \Omega$, $(V_-) + 0.2\text{ V} < V_{OUT} < (V_+) - 0.2\text{ V}$	100	120		
		$R_L = 600\ \Omega$, $T_A = -40\text{ to }+125^\circ\text{C}$	94			
	Phase margin			56		$^\circ$
FREQUENCY RESPONSE ($V_S = 5\text{ V}$)						
GBW	Gain-bandwidth product			50		MHz
SR	Slew rate			27		V/ μs
t_s	Settling time	0.1%, 4-V step		0.15		μs
		0.01%, 4-V step		0.2		
	Overdrive recovery time	$V_{IN+} \times \text{gain} > V_S$		< 0.1		μs
THD + N	Total harmonic distortion + noise ⁽⁶⁾	$V_{OUT} = 4\text{ V}_{PP}$, $f = 1\text{ kHz}$, $R_L = 600\ \Omega$		0.00025		%
	Channel-to-channel crosstalk (TLV2365 only)	$V_{OUT} = 2\text{ V}_{PP}$, $f = 100\text{ kHz}$		108		dBc
OUTPUT						
	Output voltage swing from supply rails				10	mV
		$T_A = -40^\circ\text{C to }+125^\circ\text{C}$				
I_{SC}	Short-circuit current			± 85		mA
	Capacitive load drive			See Figure 7-16		
Z_O	Open-loop output impedance	$f = 1\text{ MHz}$, $I_O = 0\text{ mA}$		40		Ω
POWER SUPPLY						
I_Q	Quiescent current per amplifier	$I_O = 0\text{ mA}$		4.6	5.8	mA
		$I_O = 0\text{ mA}$, $T_A = -40^\circ\text{C to }+125^\circ\text{C}$			6.3	

(1) Low-pass-filter bandwidth is 20 kHz for $f = 1\text{ kHz}$.

7.6 Typical Characteristics

at $T_A = 25^\circ\text{C}$, $V_S = 5\text{ V}$, $R_L = 10\text{ k}\Omega$, and gain = 1 V/V (unless otherwise noted)

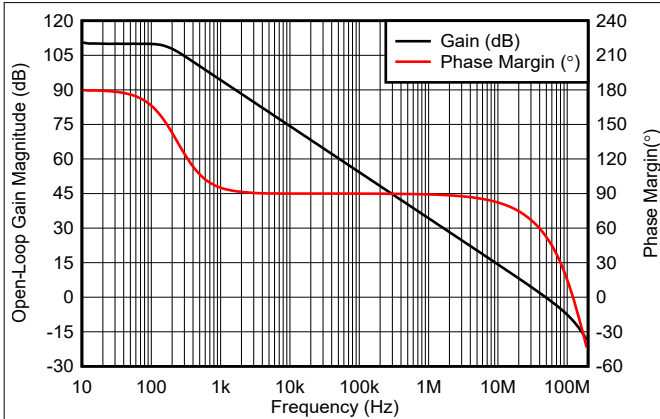

Figure 7-1. Open-Loop Gain and Phase vs Frequency

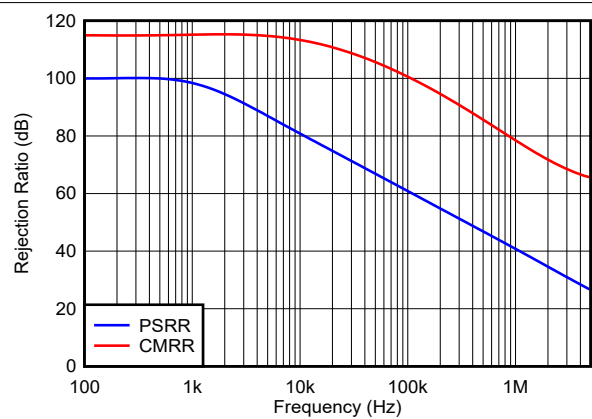

Figure 7-2. Power-Supply and Common-Mode Rejection Ratio

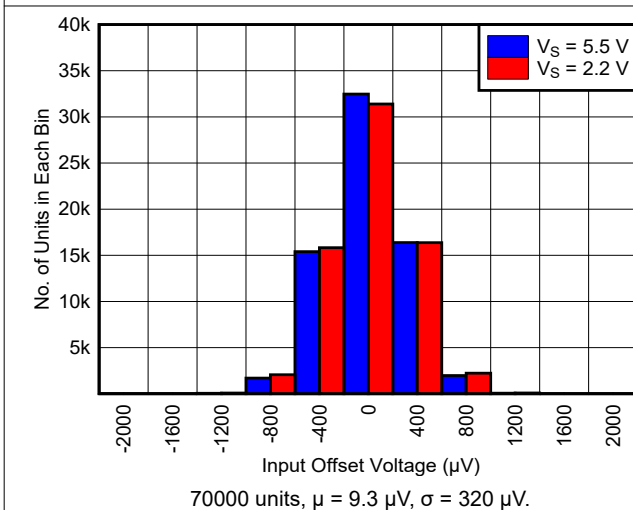

Figure 7-3. Offset Voltage Production Distribution

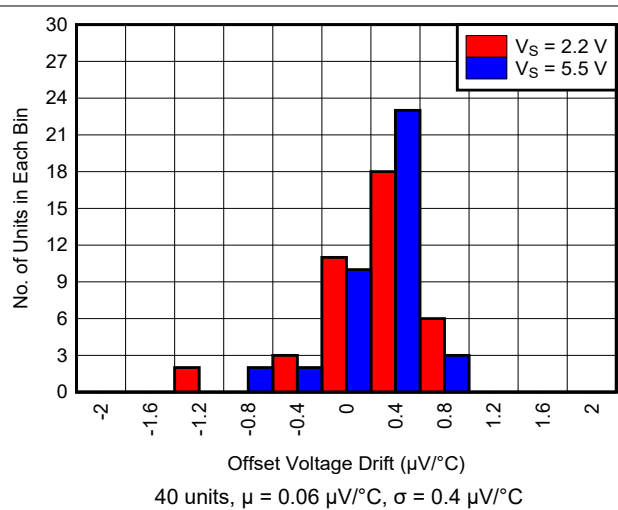

Figure 7-4. Offset Voltage Drift Distribution

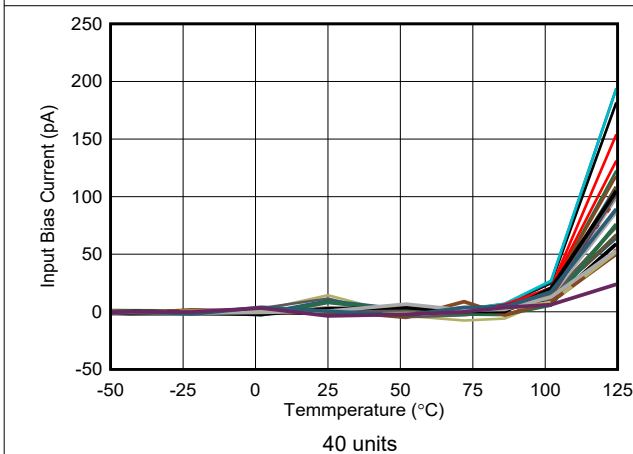

Figure 7-5. Input Bias Current vs Temperature

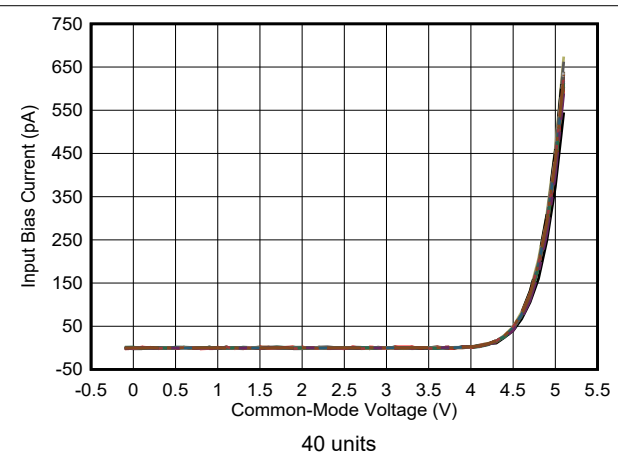

Figure 7-6. Input Bias Current vs Common-Mode Voltage

7.6 Typical Characteristics (continued)

at $T_A = 25^\circ\text{C}$, $V_S = 5\text{ V}$, $R_L = 10\text{ k}\Omega$, and gain = 1 V/V (unless otherwise noted)

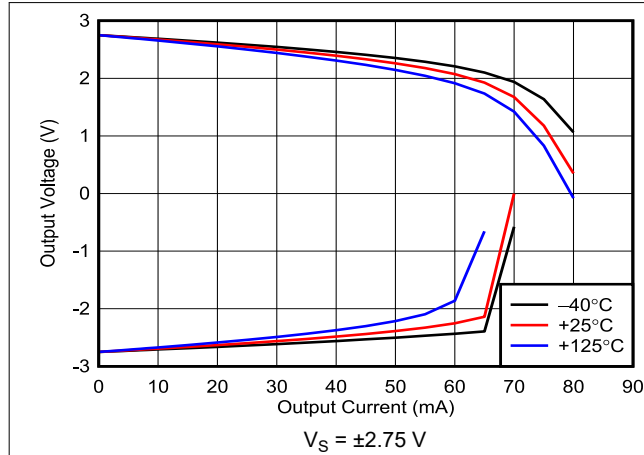

Figure 7-7. Output Voltage vs Output Current

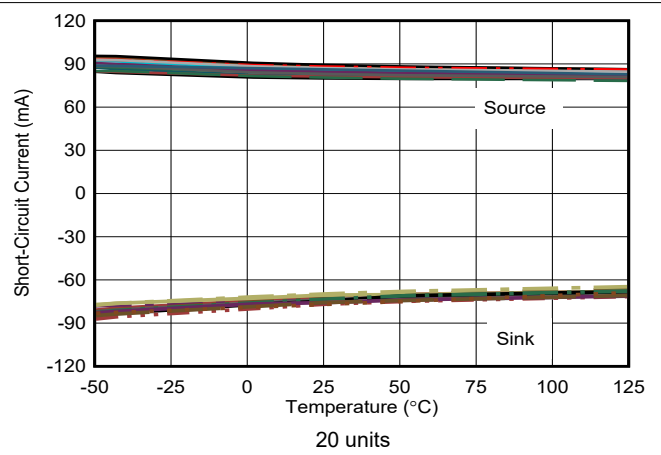

Figure 7-8. Short-Circuit Current vs Temperature

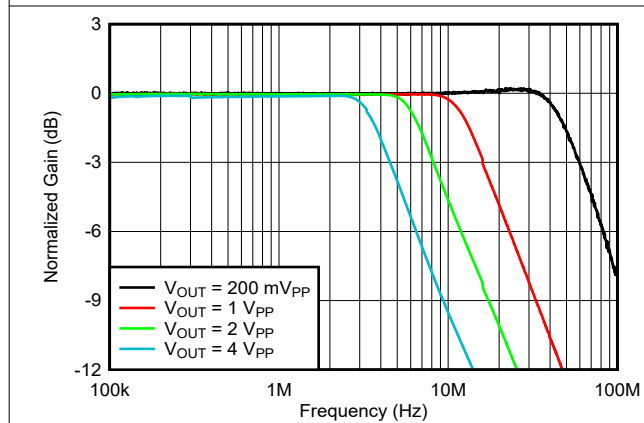

Figure 7-9. Frequency Response vs Output Voltage

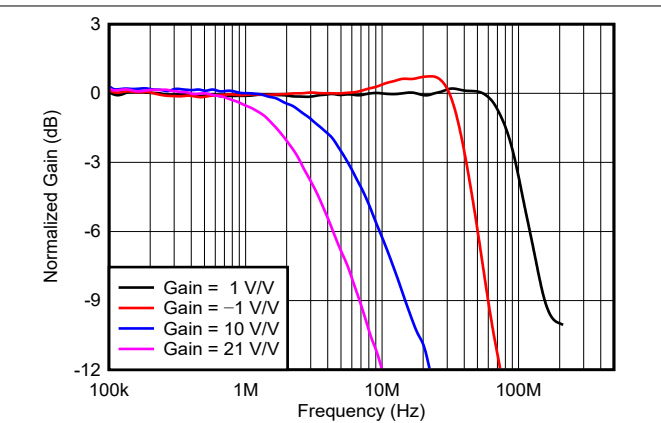

Figure 7-10. Small-Signal Frequency Response vs Gain

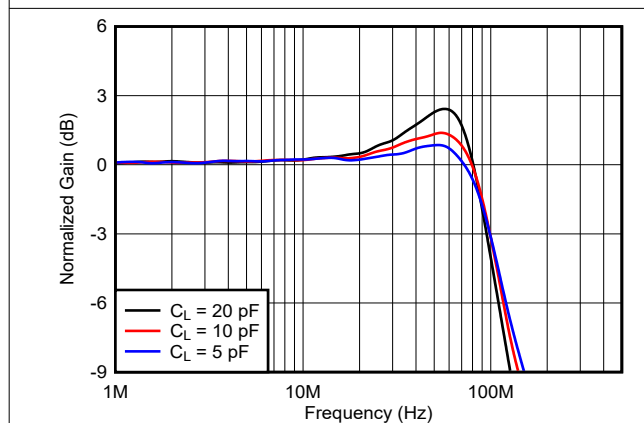

Figure 7-11. Small-Signal Response vs Capacitive Load

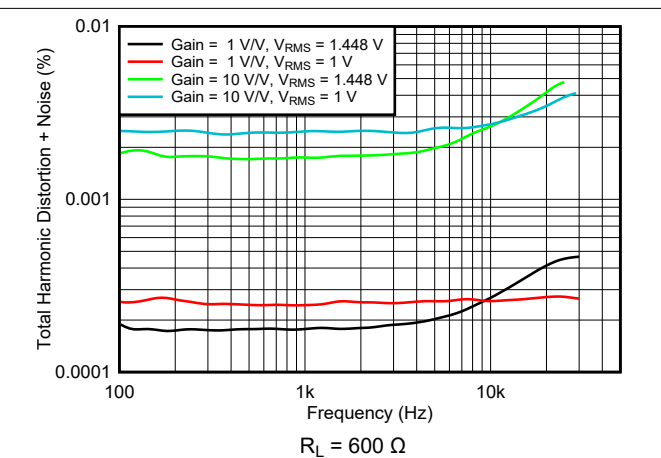

Figure 7-12. Total Harmonic Distortion + Noise vs Frequency

7.6 Typical Characteristics (continued)

at $T_A = 25^\circ\text{C}$, $V_S = 5\text{ V}$, $R_L = 10\text{ k}\Omega$, and gain = 1 V/V (unless otherwise noted)

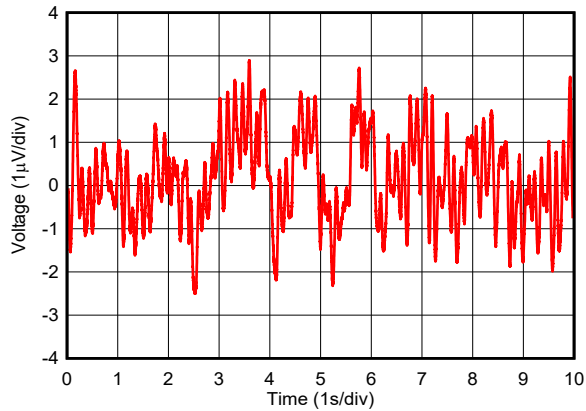

Figure 7-13. 0.1-Hz to 10-Hz Input Voltage Noise

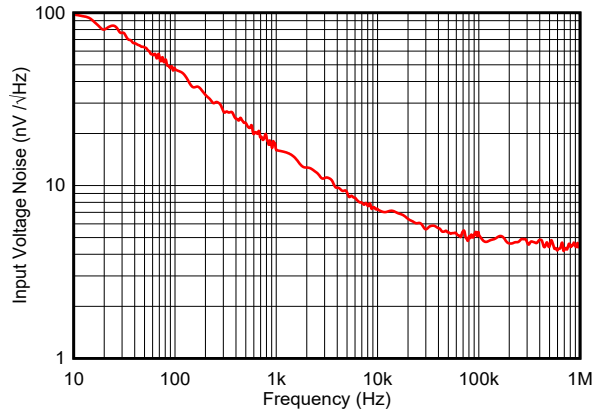

Figure 7-14. Input Voltage Noise Spectral Density

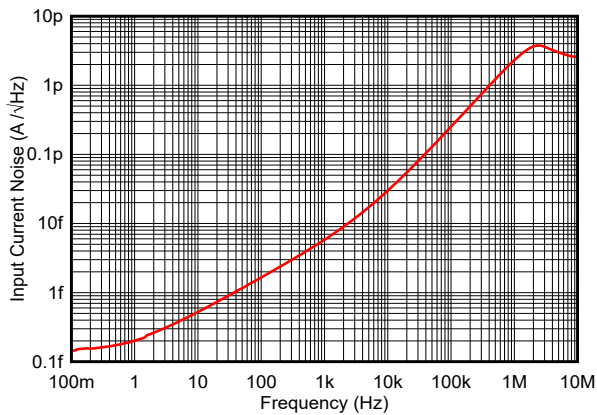
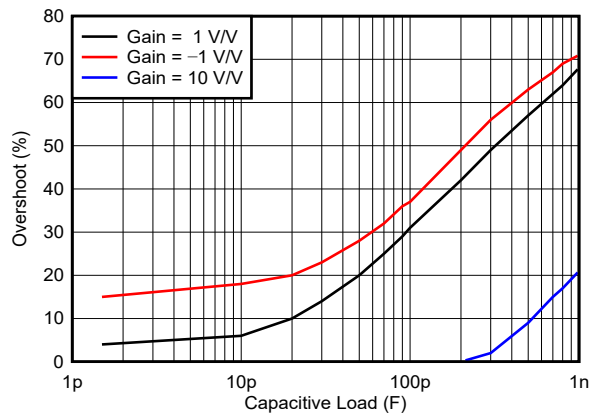

Figure 7-15. Input Current Noise Spectral Density



For gain $\neq 1\text{ V/V}$, $R_F = 1\text{ k}\Omega$. For gain = 1 V/V, $R_F = 0\ \Omega$.

Figure 7-16. Overshoot vs Capacitive Load

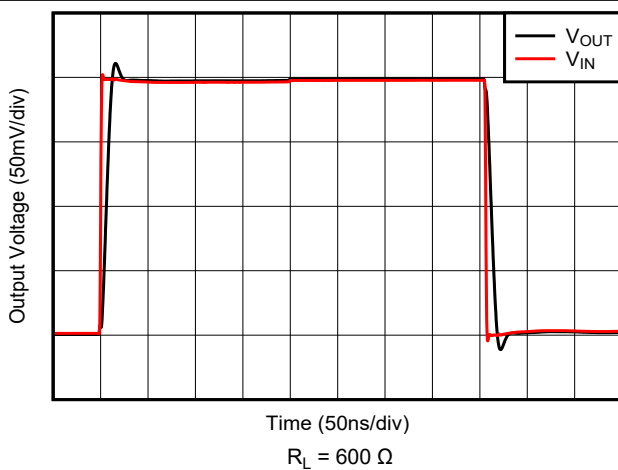

Figure 7-17. Small-Signal Step Response

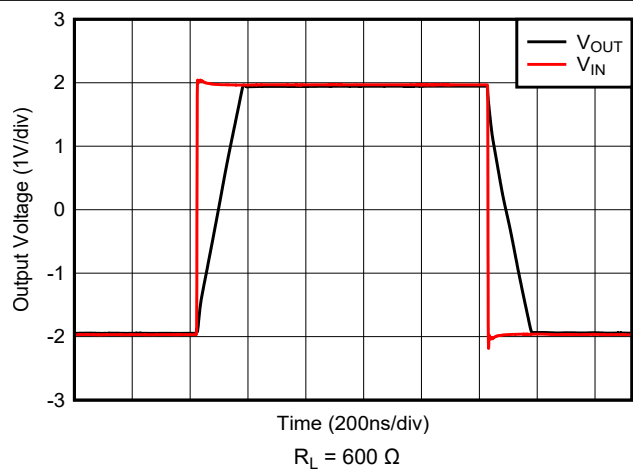

Figure 7-18. Large-Signal Step Response

7.6 Typical Characteristics (continued)

at $T_A = 25^\circ\text{C}$, $V_S = 5\text{ V}$, $R_L = 10\text{ k}\Omega$, and gain = 1 V/V (unless otherwise noted)

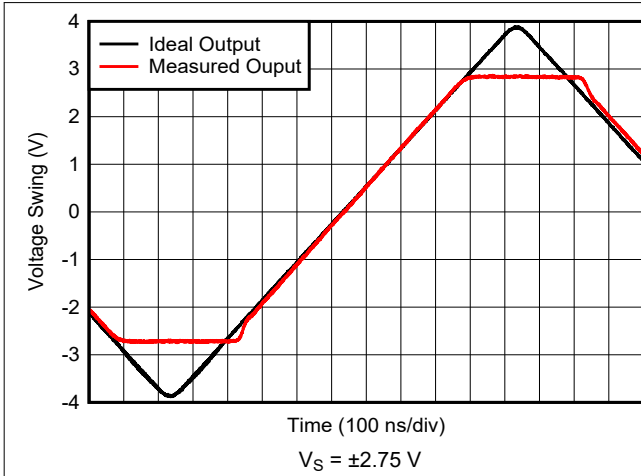

Figure 7-19. Overdrive Recovery

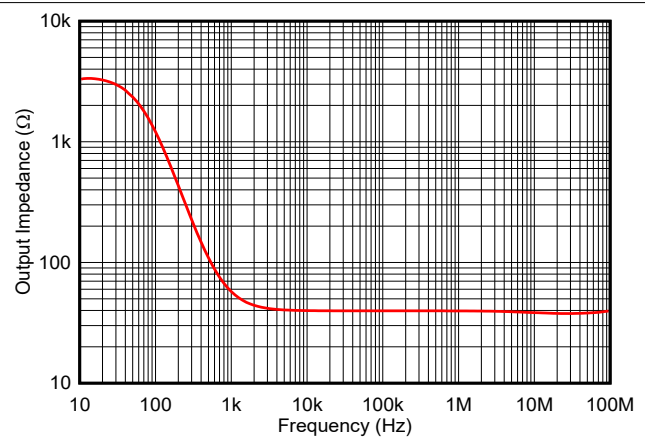

Figure 7-20. Open-Loop Output Impedance

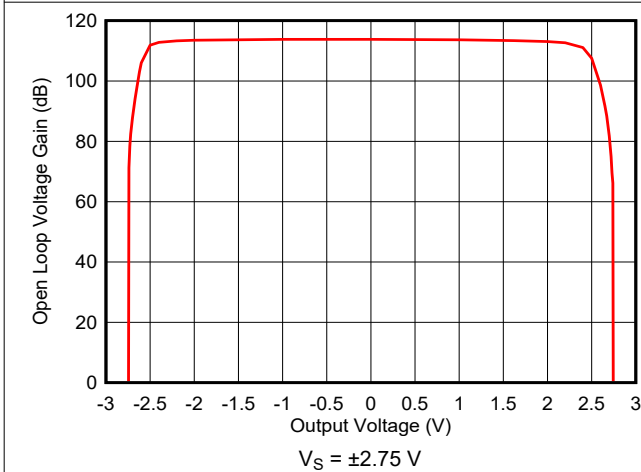

Figure 7-21. Open Loop Voltage Gain vs Output Voltage

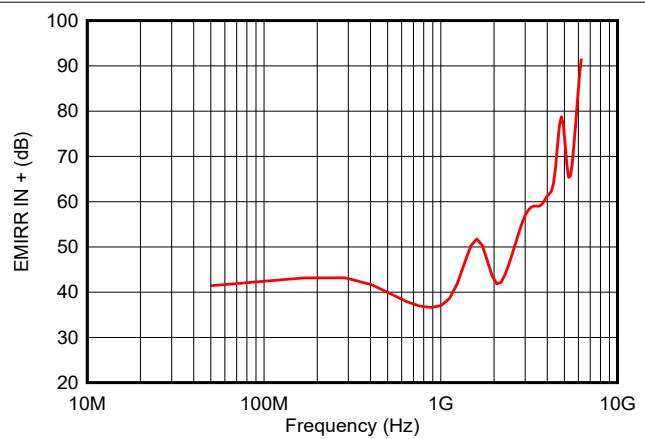

Figure 7-22. Electromagnetic Interference Rejection Ratio Referred to Noninverting Input (EMIRR $_{IN+}$) vs Frequency

8 Detailed Description

8.1 Overview

The TLVx365 series of operational amplifiers feature rail-to-rail input and output, wide-bandwidth making these devices an excellent choice for driving ADCs. Other typical applications include signal conditioning, low-side current sensing, signal buffering and sensor amplification. The TLVx365 operates with either a single supply or dual supplies.

Furthermore, the TLVx365 amplifier parameters are fully specified from 2.2 V to 5.5 V. Many of the specifications apply from -40°C to $+125^{\circ}\text{C}$.

8.2 Functional Block Diagram

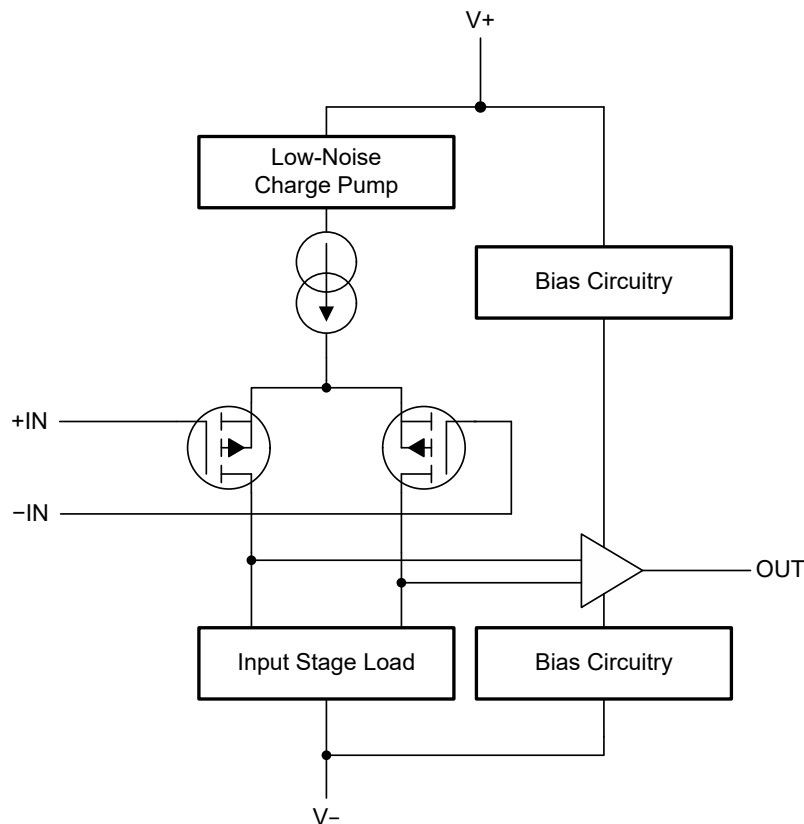

8.3 Feature Description

8.3.1 Rail-to-Rail Input

The TLVx365 product family features true rail-to-rail input operation, with supply voltages as low as ± 1.1 V (2.2 V). A unique zero-crossover input topology eliminates the input offset transition region typical of many rail-to-rail, complementary stage operational amplifiers. As shown in Figure 8-1, this topology also allows the TLVx365 to provide excellent common-mode performance over the entire input range, which extends 100 mV beyond both power-supply rails. When driving ADCs, the highly linear V_{CM} range of the TLVx365 makes sure that the system linearity performance is not compromised. For a simplified schematic illustrating the rail-to-rail input circuitry, see Section 8.2.

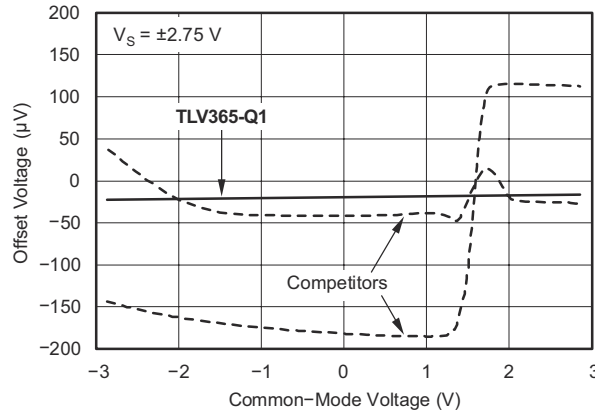

Figure 8-1. TLVx365 Linear Offset Over the Entire Common-Mode Range

8.3.2 Input and ESD Protection

Figure 8-2 shows that the TLVx365 incorporates internal electrostatic discharge (ESD) protection circuits on all pins. In the case of input and output pins, this protection primarily consists of current-steering diodes connected between the input and power-supply pins. These ESD protection diodes also provide in-circuit, input overdrive protection if the current is limited to 10 mA; see also Section 7.1. Figure 8-3 shows how a series input resistor can be added to the driven input to limit the input current. The added resistor contributes thermal noise at the amplifier input; the resistor must be kept to the minimum value in noise-sensitive applications.

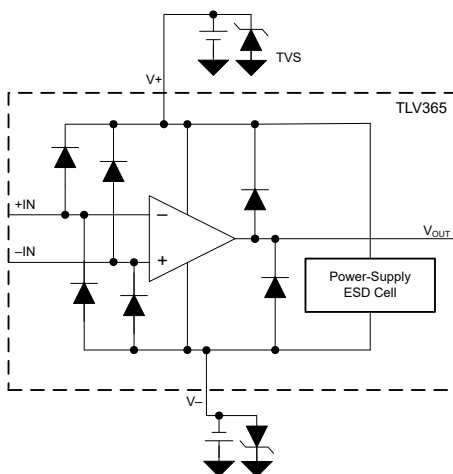

Figure 8-2. ESD Protection Scheme

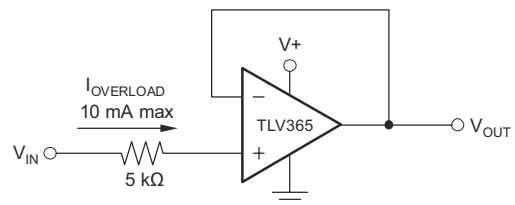

Figure 8-3. Input Current Protection

8.3.3 Driving Capacitive Loads

The TLVx365 can be used in applications where driving a capacitive load is required. An op amp in a unity-gain, buffer configuration and driving a capacitive load exhibits a greater tendency to be unstable than an amplifier operated at a higher gain. The capacitive load, in conjunction with the op-amp output impedance, creates a pole within the feedback loop that degrades the phase margin. The degradation of the phase margin increases as the capacitive loading increases.

Figure 8-4 shows one technique to increase the capacitive-load drive capability of the amplifier operating in unity gain is to insert a small resistor, R_{ISO} , in series with the output. This resistor significantly reduces the overshoot and ringing associated with capacitive loads.

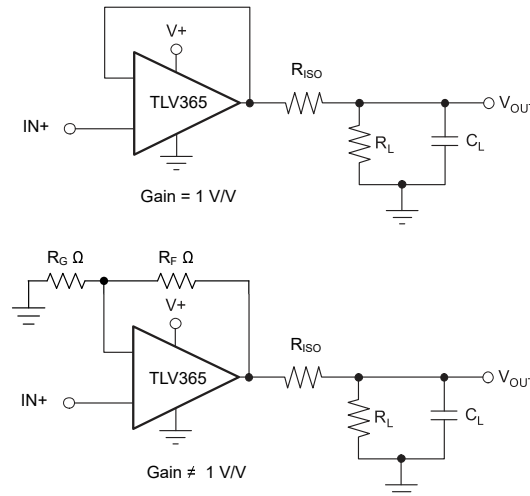

Figure 8-4. Improving Capacitive Load Drive

A possible drawback of this technique is the voltage divider created with the added series resistor (R_{ISO}) and any resistor (R_L) connected in parallel with the capacitive load. The voltage divider introduces a gain error at the output that also reduces the output swing. The error contributed by the voltage divider can be insignificant. For instance, with a load resistance of $R_L = 10\text{ k}\Omega$ and $R_{ISO} = 20\ \Omega$, the gain error is only approximately 0.2%.

Figure 8-5 shows the recommended isolation resistor (R_{ISO}) to be connected at the output of TLVx365 for different capacitive loads. The TLVx365 can drive higher capacitive loads without the need of isolation resistors at higher gains.

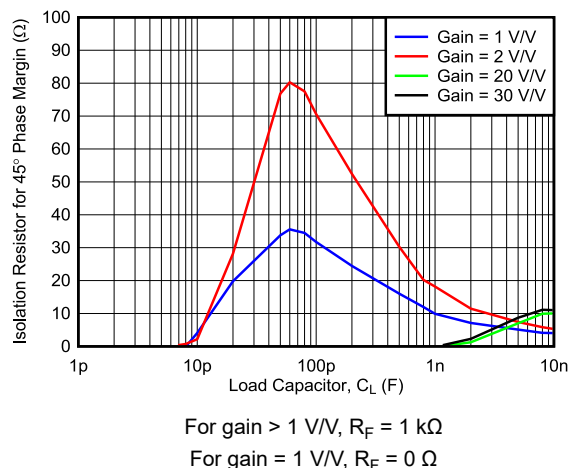

Figure 8-5. Recommended Isolation Resistor vs Capacitive Load

8.3.4 Active Filter

The TLVx365 is an excellent choice for active filter applications requiring a wide bandwidth, fast slew rate, low-noise, single-supply operational amplifier. [Figure 8-6](#) shows a 500-kHz, second-order, low-pass filter using a multiple-feedback (MFB) topology. The components have been selected to provide a maximally-flat Butterworth response. Beyond the cutoff frequency, rolloff is -40 dB/dec. The Butterworth response is designed for applications requiring predictable gain characteristics, such as the antialiasing filter used ahead of an ADC.

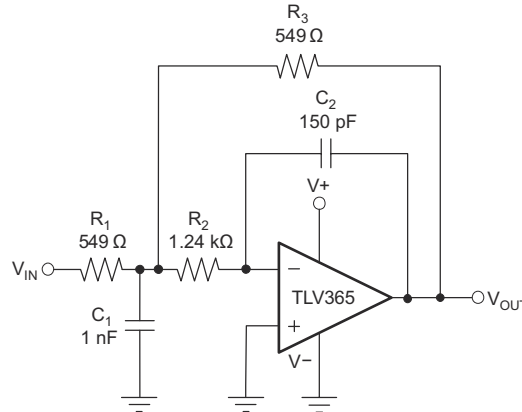

Figure 8-6. Second-Order Butterworth, 500-kHz Low-Pass Filter

When considering the MFB filter, the output is inverted, relative to the input. If this inversion is not desired, then a noninverting output can be achieved through one of these options:

- add an inverting amplifier
- add an additional second-order MFB stage
- use a noninverting filter topology, such as the Sallen-Key

[Figure 8-7](#) shows the Sallen-Key topology.

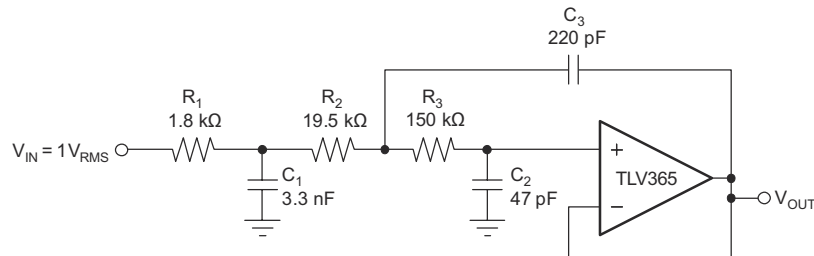

Figure 8-7. Configured as a Three-Pole, 20-kHz, Sallen-Key Filter

8.4 Device Functional Modes

The device has one mode of operation that applies when operated within the recommended operating conditions.

9 Application and Implementation

Note

Information in the following applications sections is not part of the TI component specification, and TI does not warrant its accuracy or completeness. TI's customers are responsible for determining suitability of components for their purposes, as well as validating and testing their design implementation to confirm system functionality.

9.1 Application Information

The TLVx365 offer outstanding dc and ac performance. These devices operate with up to a 5.5-V power supply, offer an ultra-low input bias current and a 50-MHz bandwidth with true rail-to-rail input capability.

9.1.1 Overdrive Recovery Performance

The TLVx365 family exhibits excellent overdrive recovery when the output is driven well beyond the $V+$ or $V-$ supplies. When configured in a low-side current-sensing configuration (as in Figure 9-1), the output of the op amp (TLVx365) is often driven to or less than ground as a result of ground bounce at the power ground or the ≤ 0 -A current being measured across shunt resistance R_{SH} . The TLVx365 has the ability to recover from an overdrive event in < 100 ns. Figure 9-2 shows the comparison of the overdrive recovery performance of TLVx365 and other popular op amps in the same category.

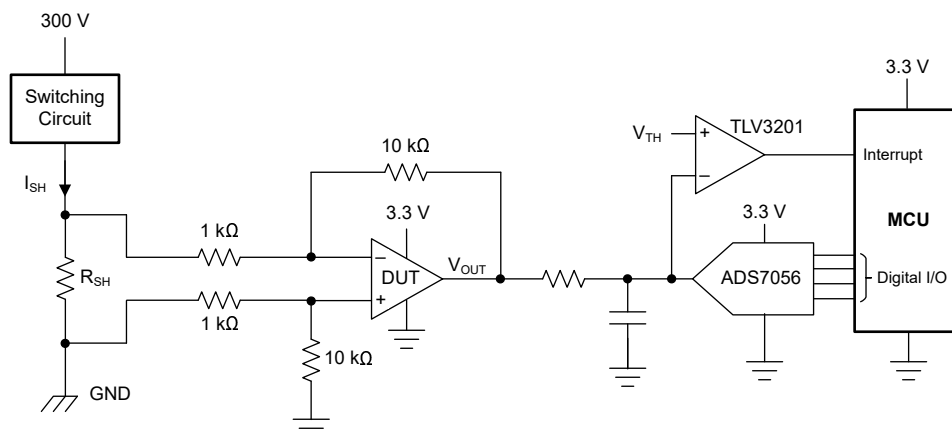
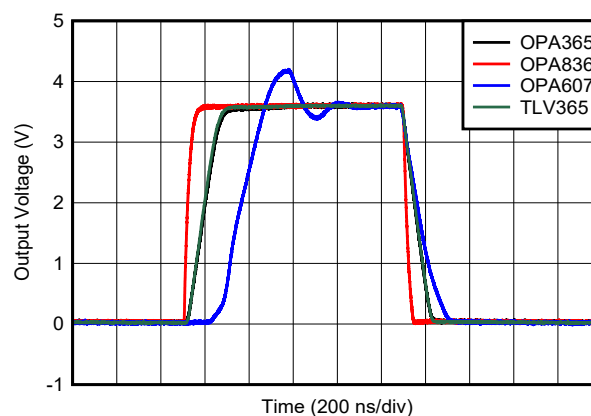

Figure 9-1. Low Side Current Sensing Application Circuit



Gain = 10 V/V. V_{OUT} driven to $(V-) - 1$ V

Figure 9-2. TLVx365 Overdrive Recovery

9.1.2 Achieving an Output Level of Zero Volts

Certain single-supply applications require the op-amp output to swing from 0 V to a positive full-scale voltage and have high accuracy. An example is an op amp employed to drive a single-supply ADC having an input range from 0 V to 3.3 V. Rail-to-rail output amplifiers with very light output loading can achieve an output level within few millivolts of 0 V (or V+ at the high end), but not true 0 V. Furthermore, the deviation from 0 V only becomes greater as the required load current increases. This increased deviation is a result of limitations of the CMOS output stage.

When a pulldown resistor is connected from the amplifier output to a negative voltage source, the TLVx365 can achieve an output level of 0 V, and even a few millivolts below 0 V. Figure 9-3 shows a circuit using this technique.

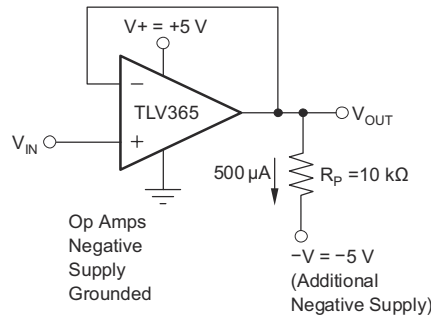

Figure 9-3. Swing-to-Ground

A pulldown current of approximately 500 μA is required when TLVx365 is connected as a unity-gain buffer. Pulldown resistor R_L is calculated from $R_L = [(V_O - V_{NEG}) / (500 \mu A)]$.

Figure 9-4 shows the offset voltage vs output swing.

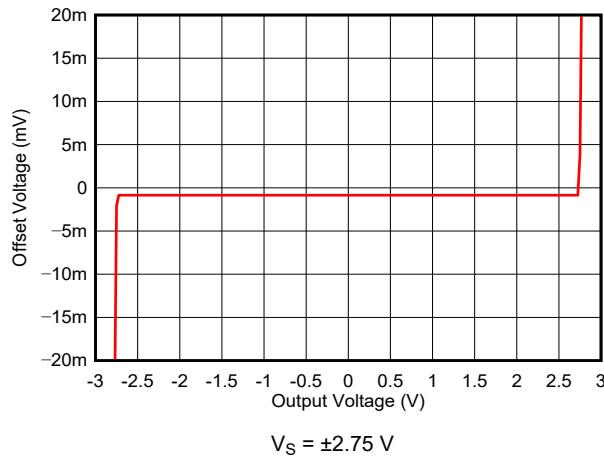
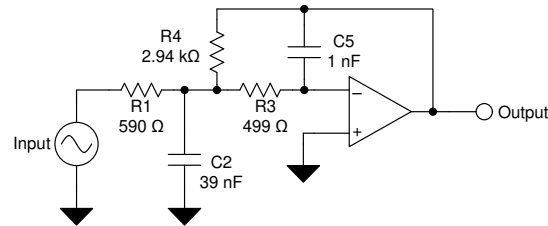

Figure 9-4. Offset Voltage vs Output Swing

9.2 Typical Applications

9.2.1 Second-Order Low-Pass Filter

Low-pass filters are commonly employed in signal processing applications to reduce noise and prevent aliasing. The TLVx365 is designed to construct high-speed, high-precision active filters. Figure 9-5 shows a second-order low-pass filter commonly encountered in signal processing applications.



Copyright © 2016, Texas Instruments Incorporated

Figure 9-5. Second-Order Low-Pass Filter

9.2.1.1 Design Requirements

Use the following parameters for this design example:

- Gain = 5 V/V (inverting gain)
- Low-pass cutoff frequency = 25 kHz
- Second-order, Chebyshev filter response with 3-dB gain peaking in the pass band

9.2.1.2 Detailed Design Procedure

Figure 9-5 shows the infinite-gain, multiple-feedback circuit for a low-pass network function. Use Equation 1 to calculate the voltage transfer function.

$$\frac{\text{Output}}{\text{Input}}(s) = \frac{-1/R_1 R_3 C_2 C_5}{s^2 + (s/C_2)(1/R_1 + 1/R_3 + 1/R_4) + 1/R_3 R_4 C_2 C_5} \quad (1)$$

This circuit produces a signal inversion. For this circuit, use Equation 2 to calculate the gain at dc and the low-pass cutoff frequency.

$$\text{Gain} = \frac{R_4}{R_1}$$

$$f_C = \frac{1}{2\pi} \sqrt{(1/R_3 R_4 C_2 C_5)} \quad (2)$$

9.2.1.3 Application Curve

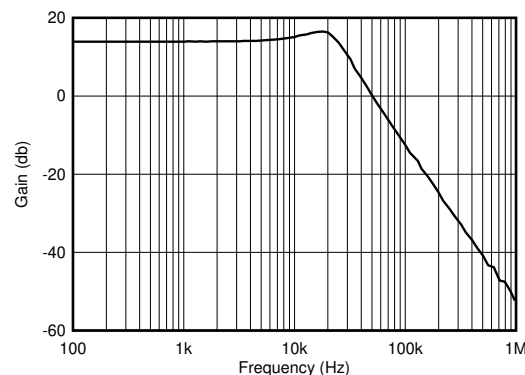

Figure 9-6. TLVx365 Second-Order 25 kHz, Chebyshev, Low-Pass Filter

9.2.2 ADC Driver and Reference Buffer

Figure 9-7 shows the use of a TLVx365 op amp as a SAR ADC input and reference pin driver. Sensors, which are used for interfacing with the physical environment, exhibit high output impedance and cannot drive SAR ADC inputs directly. The TLVx365 devices exhibit a very low-input bias current of 20 pA (maximum), and therefore do not load these high-output impedance sensors. A wide-GBW amplifier connected to the output of these sensors is needed to charge the switching capacitors at the SAR ADC input and to settle fast, to the required accuracy, within the given acquisition time.

The ADC core draws transient current from the reference input during the conversion (digitization) phase, which must be driven with a wide-GBW amplifier to offer fast settling and maintain a stable reference voltage for excellent digitization performance. The TLVx365 reference buffer is used in a composite loop with the OPA378 precision amplifier because of limitations in precision performance of wide-GBW amplifiers. The precision amplifier maintains low-offset output, whereas the TLVx365 provide the output drive and fast-settling performance.

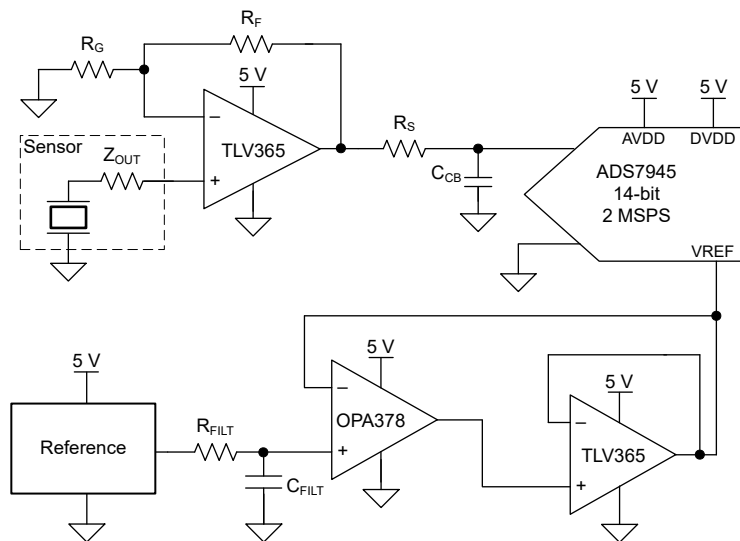

Figure 9-7. TLVx365 as a SAR ADC Driver

9.3 Power Supply Recommendations

The TLVx365 family is operational when the power-supply voltage is greater than 2.2 V (± 1.1 V). The maximum power supply voltage for the TLVx365 family is 5.5 V (± 2.75 V). The TLVx365 operate on both single and dual supplies. The maximum permissible voltage, V_S , is 6 V.

9.4 Layout

9.4.1 Layout Guidelines

For best operational performance of the device, use good printed circuit board (PCB) layout practices, including the following guidelines:

- Noise can propagate into analog circuitry through the power pins of the circuit as a whole or through the operational amplifier. Bypass capacitors are used to reduce the coupled noise by providing low-impedance power sources local to the analog circuitry.
 - Connect low-ESR, 0.1- μF ceramic bypass capacitors between each supply pin and ground, placed as close to the device as possible. A single bypass capacitor from $V+$ to ground is applicable for single-supply applications.
 - The TLVx365 is capable of peak output current (in excess of 50 mA). Applications with low impedance loads or capacitive loads with fast transient signals demand large currents from the power supplies. Larger bypass capacitors, such as 1- μF solid tantalum capacitors, can improve dynamic performance in these applications.
- Separate grounding for analog and digital portions of circuitry is one of the simplest and most-effective methods of noise suppression. One or more layers on multilayer PCBs are usually devoted to ground planes. A ground plane helps distribute heat and reduces EMI noise pickup. Make sure to physically separate digital and analog grounds paying attention to the flow of the ground current.
- To reduce parasitic coupling, run the input traces as far away from the supply or output traces as possible. If these traces cannot be kept separate, crossing the sensitive trace perpendicular is much better as opposed to in parallel with the noisy trace.
- Place the external components as close to the device as possible. Figure 9-8 shows that keeping R_F and R_G close to the inverting input minimizes parasitic capacitance.
- Keep the length of input traces as short as possible. Always remember that the input traces are the most sensitive part of the circuit.
- Consider a driven, low-impedance guard ring around the critical traces. A guard ring can significantly reduce leakage currents from nearby traces that are at different potentials.

9.4.2 Layout Example

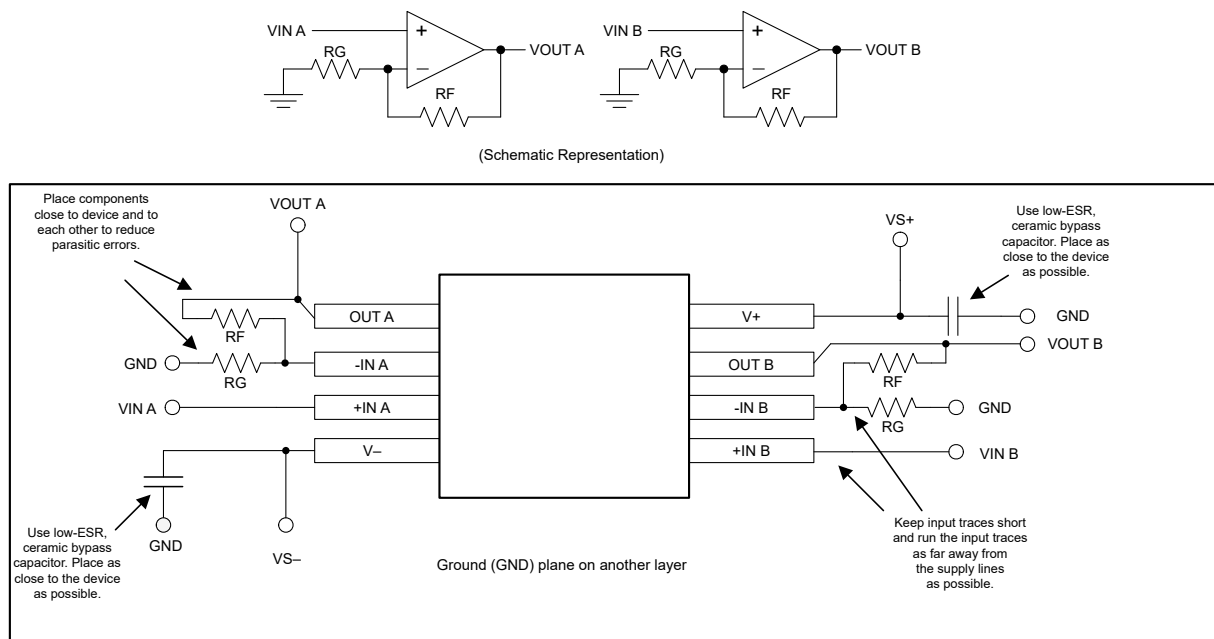

Figure 9-8. Layout Recommendation for TLV2365 SOIC Package

10 Device and Documentation Support

10.1 Device Support

10.1.1 Development Support

10.1.1.1 PSpice® for TI

PSpice® for TI is a design and simulation environment that helps evaluate performance of analog circuits. Create subsystem designs and prototype solutions before committing to layout and fabrication, reducing development cost and time to market.

10.1.1.2 TINA-TI™ Simulation Software (Free Download)

TINA-TI™ simulation software is a simple, powerful, and easy-to-use circuit simulation program based on a SPICE engine. TINA-TI simulation software is a free, fully-functional version of the TINA™ software, preloaded with a library of macromodels, in addition to a range of both passive and active models. TINA-TI simulation software provides all the conventional dc, transient, and frequency domain analysis of SPICE, as well as additional design capabilities.

Available as a [free download](#) from the [Design tools and simulation](#) web page, TINA-TI simulation software offers extensive post-processing capability that allows users to format results in a variety of ways. Virtual instruments offer the ability to select input waveforms and probe circuit nodes, voltages, and waveforms, creating a dynamic quick-start tool.

Note

These files require that either the TINA software or TINA-TI software be installed. Download the free TINA-TI simulation software from the [TINA-TI™ software folder](#).

10.1.1.3 DIP-Adapter-EVM

Speed up your op amp prototyping and testing with the [DIP-Adapter-EVM](#), which provides a fast, easy and inexpensive way to interface with small, surface-mount devices. Connect any supported op amp using the included Samtec terminal strips or wire them directly to existing circuits. The DIP-Adapter-EVM kit supports the following industry-standard packages: D or U (SOIC-8), PW (TSSOP-8), DGK (VSSOP-8), DBV (SOT-23-6, SOT-23-5 and SOT-23-3), DCK (SC70-6 and SC70-5), and DRL (SOT563-6).

10.1.1.4 DIYAMP-EVM

The [DIYAMP-EVM](#) is a unique evaluation module (EVM) that provides real-world amplifier circuits, enabling the user to quickly evaluate design concepts and verify simulations. This EVM is available in three industry-standard packages (SC70, SOT23, and SOIC) and 12 popular amplifier configurations, including amplifiers, filters, stability compensation, and comparator configurations for both single and dual supplies.

10.1.1.5 TI Reference Designs

TI reference designs are analog solutions created by TI's precision analog applications experts. TI reference designs offer the theory of operation, component selection, simulation, complete PCB schematic and layout, bill of materials, and measured performance of many useful circuits. TI reference designs are available online at <https://www.ti.com/reference-designs>.

10.1.1.6 Filter Design Tool

The [filter design tool](#) is a simple, powerful, and easy-to-use active filter design program. The filter design tool allows the user to create optimized filter designs using a selection of TI operational amplifiers and passive components from TI's vendor partners.

Available as a web-based tool from the [Design tools and simulation](#) web page, the [filter design tool](#) allows the user to design, optimize, and simulate complete multistage active filter solutions within minutes.

10.2 Documentation Support

10.2.1 Related Documentation

The following documents are relevant to using the TLVx365, and recommended for reference. All are available for download at www.ti.com unless otherwise noted.

- Texas Instruments, [FilterPro™ software user's guide](#)
- Texas Instruments, [Low Power Input and Reference Driver Circuit for ADS8318 and ADS8319 application report](#)
- Texas Instruments, [Op Amp Performance Analysis application bulletin](#)
- Texas Instruments, [Single-Supply Operation of Operational Amplifiers application bulletin](#)
- Texas Instruments, [The Best of Baker's Best – Amplifiers eBook reference book](#)

10.3 Receiving Notification of Documentation Updates

To receive notification of documentation updates, navigate to the device product folder on ti.com. Click on [Subscribe to updates](#) to register and receive a weekly digest of any product information that has changed. For change details, review the revision history included in any revised document.

10.4 Support Resources

[TI E2E™ support forums](#) are an engineer's go-to source for fast, verified answers and design help — straight from the experts. Search existing answers or ask your own question to get the quick design help you need.

Linked content is provided "AS IS" by the respective contributors. They do not constitute TI specifications and do not necessarily reflect TI's views; see TI's [Terms of Use](#).

10.5 Trademarks

TINA-TI™, FilterPro™, and TI E2E™ are trademarks of Texas Instruments.

TINA™ is a trademark of DesignSoft, Inc.

PSpice® is a registered trademark of Cadence Design Systems, Inc.

All trademarks are the property of their respective owners.

10.6 Electrostatic Discharge Caution



This integrated circuit can be damaged by ESD. Texas Instruments recommends that all integrated circuits be handled with appropriate precautions. Failure to observe proper handling and installation procedures can cause damage.

ESD damage can range from subtle performance degradation to complete device failure. Precision integrated circuits may be more susceptible to damage because very small parametric changes could cause the device not to meet its published specifications.

10.7 Glossary

[TI Glossary](#) This glossary lists and explains terms, acronyms, and definitions.

11 Mechanical, Packaging, and Orderable Information

The following pages include mechanical, packaging, and orderable information. This information is the most current data available for the designated devices. This data is subject to change without notice and revision of this document. For browser-based versions of this data sheet, refer to the left-hand navigation.

PACKAGING INFORMATION

Orderable Device	Status (1)	Package Type	Package Drawing	Pins	Package Qty	Eco Plan (2)	Lead finish/ Ball material (6)	MSL Peak Temp (3)	Op Temp (°C)	Device Marking (4/5)	Samples
OPA365AID	ACTIVE	SOIC	D	8	75	RoHS & Green	NIPDAU	Level-1-260C-UNLIM	-40 to 125	O365A	Samples
OPA365AIDBVR	ACTIVE	SOT-23	DBV	5	3000	RoHS & Green	NIPDAU	Level-1-260C-UNLIM	-40 to 125	OAVQ	Samples
OPA365AIDBVRG4	ACTIVE	SOT-23	DBV	5	3000	RoHS & Green	NIPDAU	Level-1-260C-UNLIM	-40 to 125	OAVQ	Samples
OPA365AIDBVT	ACTIVE	SOT-23	DBV	5	250	RoHS & Green	NIPDAU	Level-1-260C-UNLIM	-40 to 125	OAVQ	Samples
OPA365AIDBVTG4	ACTIVE	SOT-23	DBV	5	250	RoHS & Green	NIPDAU	Level-1-260C-UNLIM	-40 to 125	OAVQ	Samples
OPA365AIDG4	ACTIVE	SOIC	D	8	75	RoHS & Green	NIPDAU	Level-1-260C-UNLIM	-40 to 125	O365A	Samples
OPA365AIDR	ACTIVE	SOIC	D	8	2500	RoHS & Green	NIPDAU	Level-1-260C-UNLIM	-40 to 125	O365A	Samples
OPA365AIDRG4	ACTIVE	SOIC	D	8	2500	RoHS & Green	NIPDAU	Level-1-260C-UNLIM	-40 to 125	O365A	Samples
TLV2365DR	ACTIVE	SOIC	D	8	3000	RoHS & Green	NIPDAU	Level-1-260C-UNLIM	-40 to 125	T2365D	Samples
TLV365DBVR	ACTIVE	SOT-23	DBV	5	3000	RoHS & Green	Call TI NIPDAU	Level-1-260C-UNLIM	-40 to 125	T365	Samples

(1) The marketing status values are defined as follows:

ACTIVE: Product device recommended for new designs.

LIFEBUY: TI has announced that the device will be discontinued, and a lifetime-buy period is in effect.

NRND: Not recommended for new designs. Device is in production to support existing customers, but TI does not recommend using this part in a new design.

PREVIEW: Device has been announced but is not in production. Samples may or may not be available.

OBSOLETE: TI has discontinued the production of the device.

(2) **RoHS:** TI defines "RoHS" to mean semiconductor products that are compliant with the current EU RoHS requirements for all 10 RoHS substances, including the requirement that RoHS substance do not exceed 0.1% by weight in homogeneous materials. Where designed to be soldered at high temperatures, "RoHS" products are suitable for use in specified lead-free processes. TI may reference these types of products as "Pb-Free".

RoHS Exempt: TI defines "RoHS Exempt" to mean products that contain lead but are compliant with EU RoHS pursuant to a specific EU RoHS exemption.

Green: TI defines "Green" to mean the content of Chlorine (Cl) and Bromine (Br) based flame retardants meet JS709B low halogen requirements of <=1000ppm threshold. Antimony trioxide based flame retardants must also meet the <=1000ppm threshold requirement.

(3) MSL, Peak Temp. - The Moisture Sensitivity Level rating according to the JEDEC industry standard classifications, and peak solder temperature.

(4) There may be additional marking, which relates to the logo, the lot trace code information, or the environmental category on the device.

⁽⁵⁾ Multiple Device Markings will be inside parentheses. Only one Device Marking contained in parentheses and separated by a "~" will appear on a device. If a line is indented then it is a continuation of the previous line and the two combined represent the entire Device Marking for that device.

⁽⁶⁾ Lead finish/Ball material - Orderable Devices may have multiple material finish options. Finish options are separated by a vertical ruled line. Lead finish/Ball material values may wrap to two lines if the finish value exceeds the maximum column width.

Important Information and Disclaimer:The information provided on this page represents TI's knowledge and belief as of the date that it is provided. TI bases its knowledge and belief on information provided by third parties, and makes no representation or warranty as to the accuracy of such information. Efforts are underway to better integrate information from third parties. TI has taken and continues to take reasonable steps to provide representative and accurate information but may not have conducted destructive testing or chemical analysis on incoming materials and chemicals. TI and TI suppliers consider certain information to be proprietary, and thus CAS numbers and other limited information may not be available for release.

In no event shall TI's liability arising out of such information exceed the total purchase price of the TI part(s) at issue in this document sold by TI to Customer on an annual basis.

OTHER QUALIFIED VERSIONS OF OPA365, TLV365 :

- Automotive : [OPA365-Q1](#), [TLV365-Q1](#)
- Enhanced Product : [OPA365-EP](#)

NOTE: Qualified Version Definitions:

- Automotive - Q100 devices qualified for high-reliability automotive applications targeting zero defects
- Enhanced Product - Supports Defense, Aerospace and Medical Applications

TAPE AND REEL INFORMATION

QUADRANT ASSIGNMENTS FOR PIN 1 ORIENTATION IN TAPE



*All dimensions are nominal

Device	Package Type	Package Drawing	Pins	SPQ	Reel Diameter (mm)	Reel Width W1 (mm)	A0 (mm)	B0 (mm)	K0 (mm)	P1 (mm)	W (mm)	Pin1 Quadrant
OPA365AIDBVR	SOT-23	DBV	5	3000	178.0	9.0	3.3	3.2	1.4	4.0	8.0	Q3
OPA365AIDBVT	SOT-23	DBV	5	250	178.0	9.0	3.3	3.2	1.4	4.0	8.0	Q3
OPA365AIDR	SOIC	D	8	2500	330.0	12.4	6.4	5.2	2.1	8.0	12.0	Q1
TLV2365DR	SOIC	D	8	3000	330.0	12.4	6.4	5.2	2.1	8.0	12.0	Q1
TLV365DBVR	SOT-23	DBV	5	3000	180.0	8.4	3.2	3.2	1.4	4.0	8.0	Q3
TLV365DBVR	SOT-23	DBV	5	3000	180.0	8.4	3.2	3.2	1.4	4.0	8.0	Q3

TAPE AND REEL BOX DIMENSIONS

*All dimensions are nominal

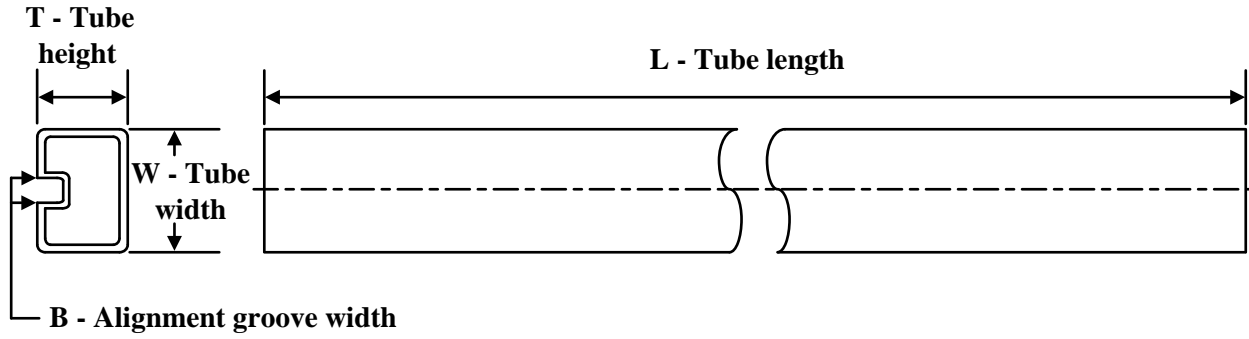
Device	Package Type	Package Drawing	Pins	SPQ	Length (mm)	Width (mm)	Height (mm)
OPA365AIDBVR	SOT-23	DBV	5	3000	180.0	180.0	18.0
OPA365AIDBVT	SOT-23	DBV	5	250	180.0	180.0	18.0
OPA365AIDR	SOIC	D	8	2500	356.0	356.0	35.0
TLV2365DR	SOIC	D	8	3000	340.5	338.1	20.6
TLV365DBVR	SOT-23	DBV	5	3000	210.0	185.0	35.0
TLV365DBVR	SOT-23	DBV	5	3000	210.0	185.0	35.0

TUBE

*All dimensions are nominal

Device	Package Name	Package Type	Pins	SPQ	L (mm)	W (mm)	T (μm)	B (mm)
OPA365AID	D	SOIC	8	75	506.6	8	3940	4.32
OPA365AIDG4	D	SOIC	8	75	506.6	8	3940	4.32

EXAMPLE BOARD LAYOUT

DBV0005A

SOT-23 - 1.45 mm max height

SMALL OUTLINE TRANSISTOR



LAND PATTERN EXAMPLE
EXPOSED METAL SHOWN
SCALE:15X



SOLDER MASK DETAILS

4214839/J 02/2024

NOTES: (continued)

- 6. Publication IPC-7351 may have alternate designs.
- 7. Solder mask tolerances between and around signal pads can vary based on board fabrication site.

EXAMPLE STENCIL DESIGN

DBV0005A

SOT-23 - 1.45 mm max height

SMALL OUTLINE TRANSISTOR



SOLDER PASTE EXAMPLE
BASED ON 0.125 mm THICK STENCIL
SCALE:15X

4214839/J 02/2024

NOTES: (continued)

8. Laser cutting apertures with trapezoidal walls and rounded corners may offer better paste release. IPC-7525 may have alternate design recommendations.
9. Board assembly site may have different recommendations for stencil design.



D0008A

PACKAGE OUTLINE

SOIC - 1.75 mm max height

SMALL OUTLINE INTEGRATED CIRCUIT



4214825/C 02/2019

NOTES:

- Linear dimensions are in inches [millimeters]. Dimensions in parenthesis are for reference only. Controlling dimensions are in inches. Dimensioning and tolerancing per ASME Y14.5M.
- This drawing is subject to change without notice.
- This dimension does not include mold flash, protrusions, or gate burrs. Mold flash, protrusions, or gate burrs shall not exceed $.006$ [0.15] per side.
- This dimension does not include interlead flash.
- Reference JEDEC registration MS-012, variation AA.

EXAMPLE BOARD LAYOUT

D0008A

SOIC - 1.75 mm max height

SMALL OUTLINE INTEGRATED CIRCUIT



LAND PATTERN EXAMPLE
 EXPOSED METAL SHOWN
 SCALE:8X



SOLDER MASK DETAILS

4214825/C 02/2019

NOTES: (continued)

- 6. Publication IPC-7351 may have alternate designs.
- 7. Solder mask tolerances between and around signal pads can vary based on board fabrication site.

EXAMPLE STENCIL DESIGN

D0008A

SOIC - 1.75 mm max height

SMALL OUTLINE INTEGRATED CIRCUIT



SOLDER PASTE EXAMPLE
BASED ON .005 INCH [0.125 MM] THICK STENCIL
SCALE:8X

4214825/C 02/2019

NOTES: (continued)

8. Laser cutting apertures with trapezoidal walls and rounded corners may offer better paste release. IPC-7525 may have alternate design recommendations.
9. Board assembly site may have different recommendations for stencil design.

IMPORTANT NOTICE AND DISCLAIMER

TI PROVIDES TECHNICAL AND RELIABILITY DATA (INCLUDING DATA SHEETS), DESIGN RESOURCES (INCLUDING REFERENCE DESIGNS), APPLICATION OR OTHER DESIGN ADVICE, WEB TOOLS, SAFETY INFORMATION, AND OTHER RESOURCES "AS IS" AND WITH ALL FAULTS, AND DISCLAIMS ALL WARRANTIES, EXPRESS AND IMPLIED, INCLUDING WITHOUT LIMITATION ANY IMPLIED WARRANTIES OF MERCHANTABILITY, FITNESS FOR A PARTICULAR PURPOSE OR NON-INFRINGEMENT OF THIRD PARTY INTELLECTUAL PROPERTY RIGHTS.

These resources are intended for skilled developers designing with TI products. You are solely responsible for (1) selecting the appropriate TI products for your application, (2) designing, validating and testing your application, and (3) ensuring your application meets applicable standards, and any other safety, security, regulatory or other requirements.

These resources are subject to change without notice. TI grants you permission to use these resources only for development of an application that uses the TI products described in the resource. Other reproduction and display of these resources is prohibited. No license is granted to any other TI intellectual property right or to any third party intellectual property right. TI disclaims responsibility for, and you will fully indemnify TI and its representatives against, any claims, damages, costs, losses, and liabilities arising out of your use of these resources.

TI's products are provided subject to [TI's Terms of Sale](#) or other applicable terms available either on [ti.com](https://www.ti.com) or provided in conjunction with such TI products. TI's provision of these resources does not expand or otherwise alter TI's applicable warranties or warranty disclaimers for TI products.

TI objects to and rejects any additional or different terms you may have proposed.

Mailing Address: Texas Instruments, Post Office Box 655303, Dallas, Texas 75265
Copyright © 2024, Texas Instruments Incorporated



Looking for pricing, stock, or lifecycle information?

Click below to explore more details on WIN SOURCE:

 [View OPA365AIDBVR](#) on WIN SOURCE

 [Texas Instruments](#) Information

Optimize Your Supply Chain with WIN SOURCE Solutions

-  Global Sourcing Solution
-  Obsolete Management
-  Cost Control Management
-  Shortage Management
-  Alternative Solution
-  Excess Inventory Management