



**THE DATASHEET OF
ACEFN103-HF**



ACEFN103-HF

Forward current: 1.0A

Reverse voltage: 600V

RoHS Device
Halogen Free

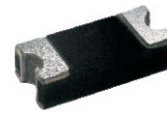

Features

- GPRC(Glass passivated rectifier chip) inside.
- Glass passivated cavity-free junction.
- Low power loss, High efficiency.
- High current capability
- Plastic package has UL 94V-0.
- Comply with AEC-Q101

Mechanical Data

- Case: Packed with FRP substrate and epoxy underfilled.
- Terminals: Pure Tin plated (Lead-Free),solderable per MIL-STD-750, method 2026.
- Polarity: Laser cathode band marking.
- Weight: 0.012 grams(approx).

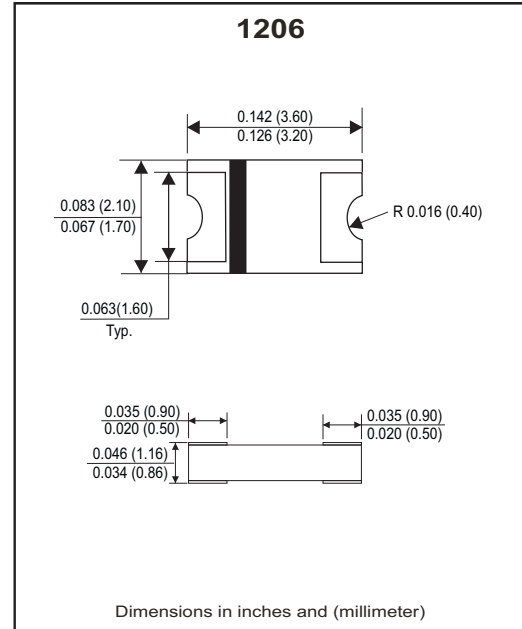

Circuit diagram



Absolute Maximum Ratings (at TA=25°C unless otherwise noted)

Parameter	Conditions	Symbol	ACEFN103-HF	Units
		Marking	167 Z.	
Repetitive peak reverse voltage		V_{RRM}	600	V
Average forward current	$T_L=110^{\circ}C$	$I_{F(AV)}$	1.0	A
Peak forward surge current	8.3ms single half sine-wave	I_{FSM}	25	A
Reverse recovery time	$I_F=0.5A, I_R=1.0A, I_{rr}=0.25A$	T_{rr}	35	nS
Operating junction temperature		T_J	-65 to +175	$^{\circ}C$
Storage temperature		T_{STG}	-65 to +175	$^{\circ}C$

Electrical Characteristics (at TA=25°C unless otherwise noted)

Parameter	Conditions	Symbol	MIN.	TYP.	MAX.	Unit
Forward voltage	$I_F=0.1A$	V_F	-	0.80	-	V
	$I_F=0.5A$		-	1.15	-	
	$I_F=1.0A$		-	1.40	1.70	
Repetitive peak reverse current	$V_R = \text{Max. } V_{RRM}, T_A=25^{\circ}C$	I_{RRM}	-	0.20	5	μA
Junction capacitance	$V_R=4V, f=1.0MHz$	C_J	-	10	-	pF
Thermal Resistance	Junction to ambient (Note)	$R_{\theta JA}$	-	80	-	$^{\circ}C/W$
	Junction to lead (Note)	$R_{\theta JL}$	-	40	-	

Notes: 1. Thermal resistance from junction to ambient and from junction to lead P.C.B. mounted on 0.2x0.2"(5.0*5.0mm) copper pad areas.

Company reserves the right to improve product design , functions and reliability without notice.

REV:B

RATING AND CHARACTERISTIC CURVES (ACEFN103-HF)

Fig.1- Forward current derating curve

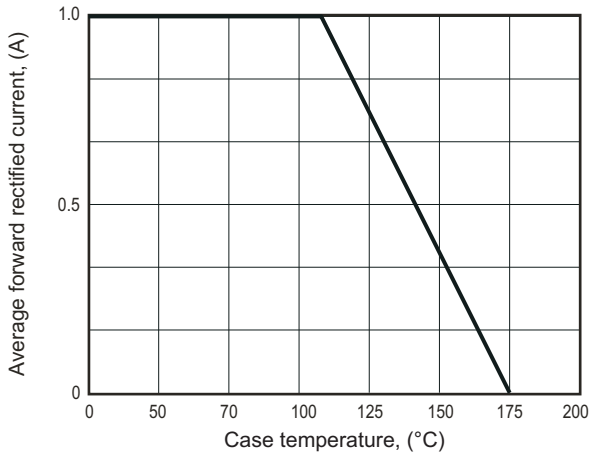

Fig.2- Maximum non-repetitive peak forward surge current

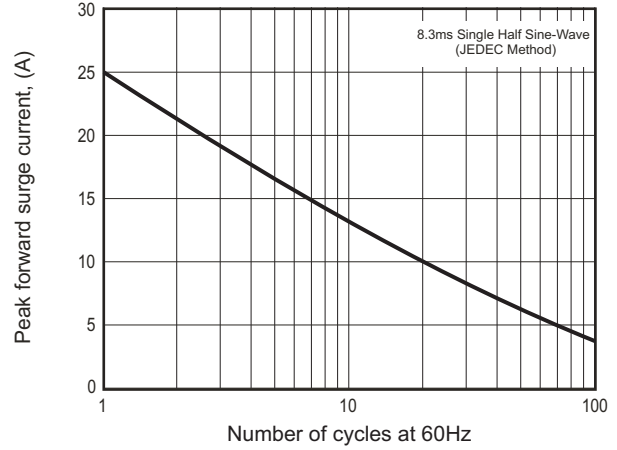

Fig.3- Typical instantaneous forward characteristics

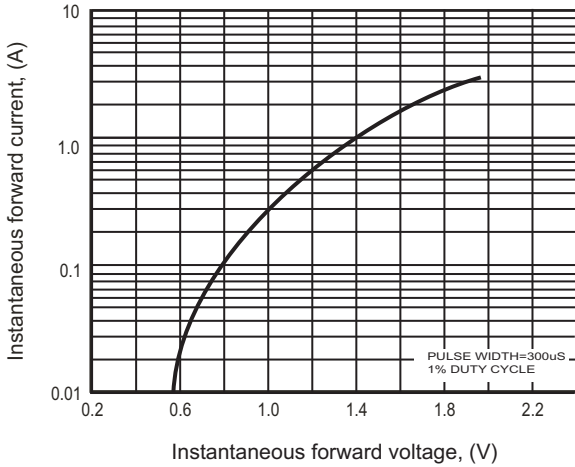

Fig.4- Typical Reverse Characteristics

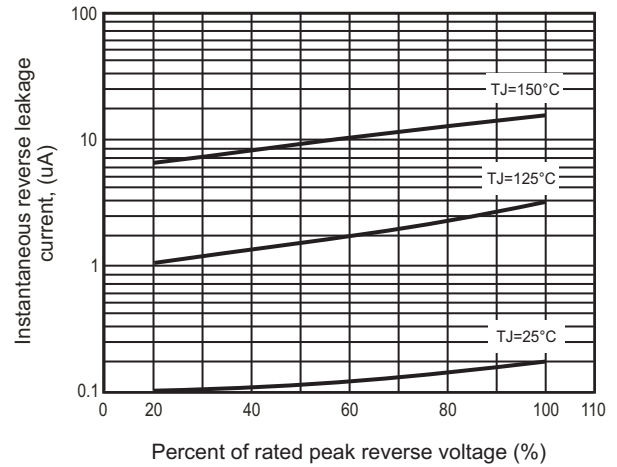
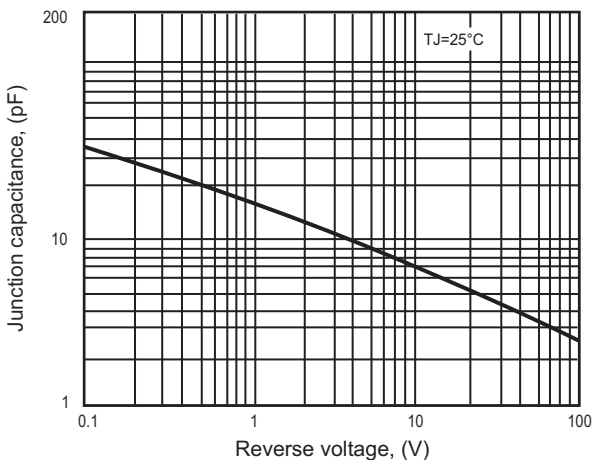
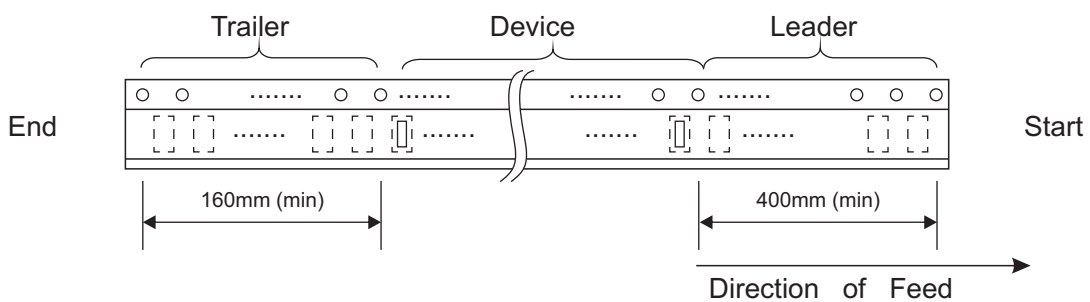
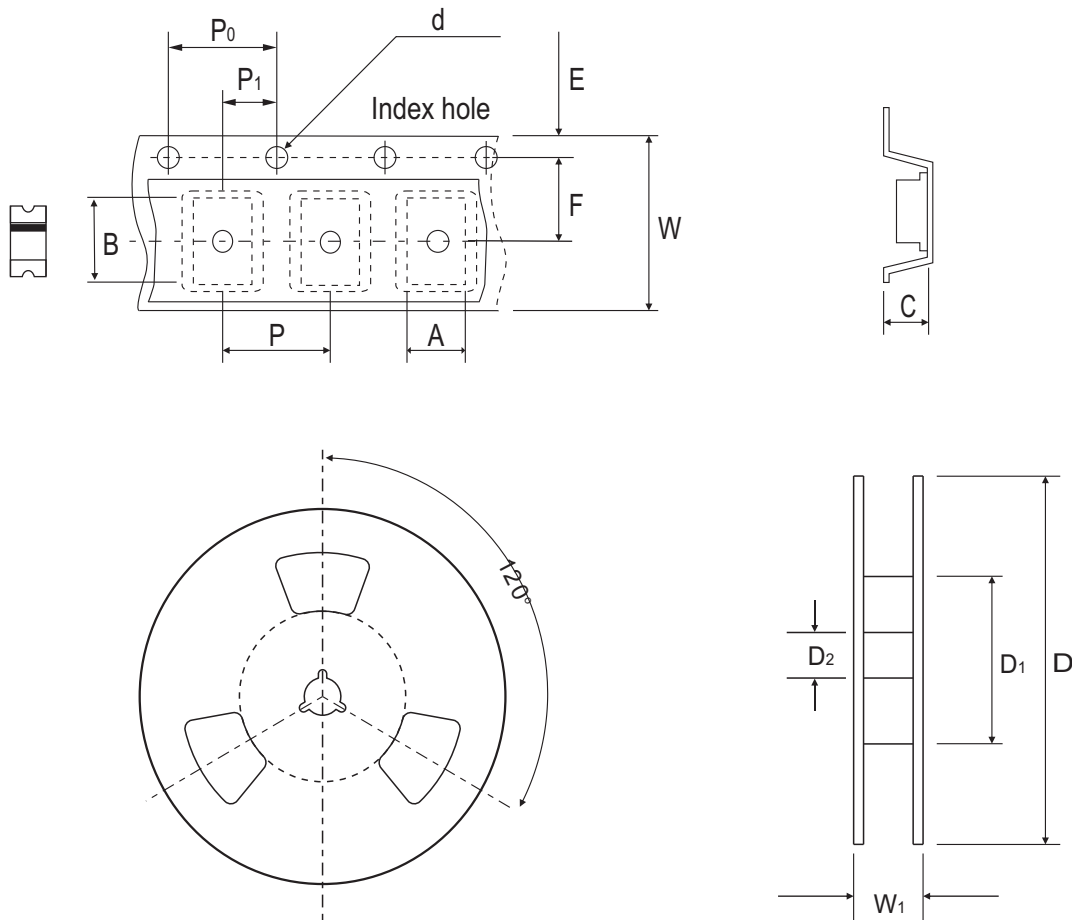

Fig.5 - Typical junction capacitance



Reel Taping Specification



1206	SYMBOL	A	B	C	d	D	D ₁	D ₂
	(mm)	2.20 ± 0.10	3.65 ± 0.10	1.28 ± 0.10	1.50 ± 0.10	178.00 ± 2.00	50.00 MIN.	13.00 ± 0.50
	(inch)	0.087 ± 0.004	0.144 ± 0.004	0.050 ± 0.004	0.059 ± 0.004	7.008 ± 0.079	1.969 MIN.	0.512 ± 0.020

1206	SYMBOL	E	F	P	P ₀	P ₁	W	W ₁
	(mm)	1.75 ± 0.10	5.50 ± 0.05	4.00 ± 0.10	4.00 ± 0.10	2.00 ± 0.10	12.00 ± 0.30	18.70 MAX.
	(inch)	0.069 ± 0.004	0.217 ± 0.002	0.157 ± 0.004	0.157 ± 0.004	0.079 ± 0.004	0.472 ± 0.012	0.736 MAX.

Marking Code

Part Number	Marking Code
ACEFN103-HF	167 .Z.

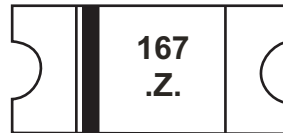

Suggested PAD Layout

SIZE	1206	
	(mm)	(inch)
A	1.50MIN.	0.059MIN.
B	1.00MIN.	0.039MIN.
C	2.00MAX.	0.079MAX.
D	4.00REF.	0.157 REF.

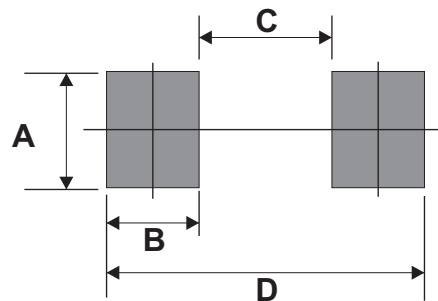

Standard Packaging

Case Type	REEL PACK	
	REEL (pcs)	Reel Size (inch)
1206	3,000	7

Looking for pricing, stock, or lifecycle information?

Click below to explore more details on WIN SOURCE:

- ⊖ [View ACEFN103-HF](#) on WIN SOURCE
- ⊖ [Comchip Technology](#) Information

Optimize Your Supply Chain with WIN SOURCE Solutions

- ✓ Global Sourcing Solution
- ✓ Obsolete Management
- ✓ Cost Control Management
- ✓ Shortage Management
- ✓ Alternative Solution
- ✓ Excess Inventory Management